

# MASTER PLAN WINCHESTER

### GENERAL NOTES:

THE FOLLOWING TECHNICAL CODES SHALL APPLY:  
2020 FLORIDA BUILDING CODE,  
PLUMBING, MECHANICAL, FUEL GAS,  
ENERGY EFFICIENCY, ACCESSIBILITY,  
AND NATIONAL ELECTRICAL CODES  
NEC 2017

- TANK TYPE WATER CLOSET VOLUME  
1.8 GALLONS
- WALL MOUNT WATER CLOSET VOLUME  
3.5 GALLONS
- WATER - FLOW RATE.  
PUBLIC FACILITIES 0.5 G.P.M.  
PRIVATE FACILITIES 2.2 G.P.M.  
SHOWER HEADS 2.5 G.P.M.

VTR LOCATIONS ARE APPROXIMATE  
AND MAY CHANGE DUE TO JOBSITE  
CONDITIONS

THE FOLLOWING SHALL COMPLY  
WITH THE 2017 FBC.

- PORCHES AND BALCONIES
- HANDRAILS
- GUARDRAILS
- STAIRS
- CHIMNEY & FIREPLACE
- EGRESS WINDOWS

- ALL OPENINGS SHALL COMPLY WITH  
2017 FBC WIND LOADS AS STATED  
BELOW. ATTACHMENTS OF WINDOWS,  
DOORS, SLIDING GLASS DOORS  
AND O.H. GARAGE DOORS ARE DELEGATED  
THE MANUFACTURER OF THESE ITEMS. THE  
MANUFACTURER OF THESE ITEMS  
SHALL SUBMIT ATTACHMENTS TO ENGINEER  
OF RECORD FOR REVIEW PRIOR TO INSTALLATION.  
SEE ATTACHED SPECIFICATION SHEETS FOR  
MANUFACTURERS DESIGN CRITERIA AND  
INSTALLATION METHODS FOR WINDOWS,  
DOORS, SLIDING GLASS DOORS, OVERHEAD  
GARAGE DOORS, AND ROOFING.
- ALL DOORS INTERIOR & EXTERIOR ARE  
8' 0" UNLESS OTHERWISE NOTED  
ALL SHOWER ENCLOSURES TO BE  
TEMPERED GLASS
- ALL WINDOWS WITHIN 24" OF DOORS  
(INTERIOR & EXTERIOR) AND WITHIN  
18" OFF FLR TO BE TEMPERED GLASS.

**SOFTPLAN**  
ARCHITECTURAL DESIGN SOFTWARE

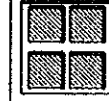

**ROBBIAN DESIGN**  
AL ROBBIAN A.I.B.D.  
6397 CONNORWOOD SQ.  
NEW PORT RICHEY, FL. 34653  
(727) 848-2359  
MAIL-4@robbiandesign.com

**AI** AIBD  
7059 Blair Road NW  
Suite 201  
**BD**® Washington DC 20012

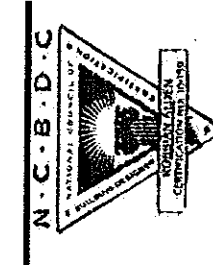

ALLEN ENGINEERING AND CONSTRUCTION SERVICES, INC. (AECS) IS NOT  
RESPONSIBLE FOR THE ARCHITECTURAL DESIGN, ITS FEATURES AND  
ASSOCIATED DIMENSIONS. THE ARCHITECTURAL INFORMATION IS ACCEPTED  
AS BEING ACCURATE AND IS USED BY AECS SOLELY FOR THE PURPOSE OF  
DETERMINING STRENGTH, FIRE PROTECTION, AND FLOOD RESISTANCE  
CONSTRUCTION REQUIREMENTS.

### INDEX OF DRAWINGS

SHEET	TITLE
S	COVER SHEET
S1	STRUCTURAL ENGINEER NOTES
S2	STRUCTURAL ENGINEER NOTES
S3	STRUCTURAL ENGINEER NOTES
S4	WIND LOAD DESIGN DATA
1	SLAB PLAN
2	FLOOR PLAN NOTES
3	DIMENSION PLAN
4	EXTERIOR ELEVATIONS
5	N/A
6	ROOF PLAN
6A	TRUSS PLAN
7	ELECTRICAL PLAN
8	CONSTRUCTION DETAILS
9	CONSTRUCTION DETAILS
10	TYPICAL WALL SECTIONS
11	TYPICAL FOOTING DETAILS
12	TYPICAL INTERIOR DETAILS

### NOTICE TO SUBCONTRACTORS :

DUE TO SPACE LIMITATIONS IN THIS 11"X 17" PLAN  
FORMAT, AND TO ELIMINATE CLUTTER AND TEXT  
READABILITY ISSUES, SOME DETAILS AND NOTATIONS  
MAY OR MAY NOT BE LOCATED ON THE SAME SHEETS  
OR IN THE SAME LOCATIONS AS PROVIDED FOR BY  
OTHER CONTRACTORS OR ARCHITECTS.  
IT WOULD BE IN YOUR BEST INTEREST TO REVIEW THESE  
PLANS AND LOCATE THE APPROPRIATE INFORMATION  
REQUIRED TO COMPLETE YOUR SPECIFIC PORTION OF  
THE JOB BEFORE BEGINNING CONSTRUCTION.

### NOTICE TO BUILDER

IT IS THE INTENT OF THIS DESIGNER THAT  
THESE PLANS ARE ACCURATE AND ARE  
CLEAR ENOUGH FOR THE LICENSED PROFESSIONAL  
TO CONSTRUCT THIS PROJECT.  
IN THE EVENT THAT SOMETHING IS UNCLEAR  
OR NEEDS CLARIFICATION, STOP AND CALL  
THE DESIGNER LISTED IN THIS TITLE PAGE. IT  
IS THE RESPONSIBILITY OF THE LICENSED  
PROFESSIONAL THAT IS CONSTRUCTING THIS  
PROJECT TO FULLY REVIEW THESE DOCUMENTS  
BEFORE CONSTRUCTION BEGINS AND ANY AND  
ALL CORRECTIONS, IF NEEDED, TO BE MADE  
BEFORE ANY WORK IS DONE.

### WINDOW INSTALLATION NOTES:

- WINDOWS MUST BE FASTENED INTO STRUCTURAL MEMBERS  
PER MFG'S. DETAIL REQUIREMENTS PER DESIGN CRITERIA  
NOTED ON THESE DRAWINGS.
- WINDOWS ARE IMPACT RESISTANT TYPE. NO STORM  
SHUTTERS OR PANELS ARE REQUIRED.
- ROOF, WALLS AND WINDOW FASTENINGS MUST BE  
ENGINEERED AND SPECIFIED FOR CUMULATIVE INTERNAL  
PRESSURE AND EXTERNAL NEGATIVE ( SUCTION ) PRESSURES  
WHICH VARIES ACCORDING TO AREAS AS NOTED IN THE DESIGN  
CRITERIA AS NOTED ON PAGE S4.

COVER SHEET



DEEB FAMILY  
HOMES, LTD.

PLAN DATE

02-24-2021

**BUILDING 63**  
RESERVE AT HUNTERS RIDGE  
PHASE THREE

A.E.C.S. 21019

WINDCHESTER MODEL

HEREBY CERTIFY THAT I HAVE  
PERFORMED THE ATTACHED DESIGN  
TO COMPLY WITH 145 MPH ULTIMATE  
WIND LOADS AND IT IS IN COMPLIANCE  
WITH SECT. 301 OF THE 2020 FLORIDA  
RESIDENTIAL BUILDING CODE  
SEALED FOR STRUCTURE ONLY  
SIGNED: *[Signature]*  
RICHARD E. ALLEN P.E. #66920

ALLEN ENGINEERING &  
CONSTRUCTION SERVICES  
RICH ALLEN PROFESSIONAL ENGINEER  
P.E. # 56920 C.A. # 9542

P.O. BOX 351  
NEW PORT RICHEY, FL. 34656  
727-842-6100  
rhal15npe@gmail.com

**STRUCTURAL ENGINEER DESIGN NOTES**

**ADMINISTRATIVE**

1. THE ENGINEERING FIRM FOR THIS STRUCTURAL DESIGN IS ALLEN ENGINEERING AND CONSTRUCTION SERVICES, INC. HEREIN REFERRED TO AS "AECS OR "A.E.C.S".

2. THE ENGINEER FOR THIS STRUCTURAL DESIGN IS RICHARD E. ALLEN, PE. HEREIN REFERRED TO AS "STRUCTURAL ENGINEER".

3. THE STRUCTURAL ENGINEER DESIGN NOTES ARE PART OF THE STRUCTURAL DESIGN AND ARE TO BE TAKEN AS TYPICAL REQUIREMENTS UNLESS NOTED OTHERWISE, "UNO", IN THE STRUCTURAL PLANS AND STRUCTURAL DETAILS.

4. THE DESIGN SHOWN IN THESE PLANS CONFORM TO THE STRUCTURAL PROVISIONS OF THE CHAPTER 16 OF THE FLORIDA BUILDING CODE, SECTION R301 OF THE FLORIDA RESIDENTIAL BUILDING CODE 2020, THE SECTIONS TITLED "STRUCTURAL" OF THE FLORIDA EXISTING BUILDING CODE 2020.

5. THE PURPOSE OF THESE PLANS IS TO OBTAIN A BUILDING PERMIT AND FOR SUBSEQUENT CONSTRUCTION OF THE DESIGN AS SHOWN. THESE PLANS ARE TO BE CONSIDERED VOID IF WORK COMMENCES PRIOR TO A PERMIT BEING ISSUED, A CHANGE IN THE BUILDING CODE OCCURS PRIOR TO THE PLANS BEING SUBMITTED FOR PERMIT OR AFTER SIX MONTHS OF THE DATE THAT THESE PLANS ARE SIGNED AND SEALED WITHOUT BEING SUBMITTED FOR PERMITTING, WHICH EVER OCCURS FIRST. ONCE A BUILDING PERMIT HAS BEEN ISSUED BASED ON THESE PLANS, THE BUILDING DEPARTMENT IS NOT AUTHORIZED TO REISSUE OR TRANSFER BUILDING PERMITS WITHOUT THE EXPRESSED WRITTEN CONSENT OF THE STRUCTURAL ENGINEER.

6. CONSTRUCTION BASED ON THE STRUCTURAL DESIGN IS TO BE DONE AS SHOWN IN THE PLANS WITHOUT DEVIATION, CHANGE OR OMISSION WITHOUT PRIOR APPROVAL OF THE STRUCTURAL ENGINEER. IF ADDITIONAL DETAIL INFORMATION, OR EXPLANATION IS NEEDED, IT IS TO BE OBTAINED FROM THE STRUCTURAL ENGINEER. THE STRUCTURAL ENGINEER IS NOT RESPONSIBLE FOR ANY ADDITIONAL PARTS OF THESE PLANS, INCLUDING PROVISIONS AS STATED IN ITEM 4.

7. IT IS IMPORTANT TO UNDERSTAND THAT STRUCTURAL PROVISIONS OF THE BUILDING CODE ARE COMPLICATED AND THESE PLANS ARE INTENDED TO BE USED BY AN EXPERIENCED BUILDING CONTRACTOR. PROPERTY OWNERS OBTAINING OWNER-BUILDER PERMITS ARE PROCEEDING AT THEIR OWN RISK. THE STRUCTURAL ENGINEER IS NOT RESPONSIBLE FOR ANY ERRORS OR OMISSIONS BY PROPERTY OWNERS OR THEIR AGENTS AS A RESULT OF ANY MISUNDERSTANDING OF THE PLANS THE OTHERWISE WOULD BE UNDERSTOOD BY A LICENSED CONTRACTOR.

8. THE STRUCTURAL ENGINEER IS NOT RESPONSIBLE FOR CONSTRUCTION MEANS, METHODS, AND SCHEDULE.

9. THE STRUCTURAL PLANS AND ANY RELEVANT DESIGN DOCUMENTS PRODUCED UNDER THE DIRECT CHARGE OF THE STRUCTURAL ENGINEER ARE THE PROPERTY OF THE STRUCTURAL ENGINEER AND MAY NOT BE USED BY ANY PERSON OTHER THAN THE CONTRACTED CLIENT AND FOR ANY PURPOSE OTHER THAN THAT STATED IN ITEM 5 ABOVE WITHOUT THE EXPRESSED WRITTEN CONSENT OF THE STRUCTURAL ENGINEER. MOREOVER, NO OTHER ENGINEER OR ARCHITECT IS TO BE DESIGNATED A DELEGATED ENGINEER FOR ANY PURPOSE RELATED TO THESE STRUCTURAL PLANS OR CONSTRUCTION BASED ON THESE PLANS PRIOR TO THE ISSUANCE OF A CERTIFICATE OF COMPLETION OR OCCUPANCY WITHOUT THE EXPRESSED WRITTEN CONSENT OF THE STRUCTURAL ENGINEER.

**DESIGN CRITERIA**

10. LOAD COMBINATIONS : THIS DESIGN IS BASED ON AN "ALLOWABLE -STRESS" FORMULATION RELYING ON THE LOAD COMBINATIONS DEFINED IN FBC 2020 SECTION 1605.3.1 OR SECTION 1605.3.2 WHERE OMEGA EQUALS 1.3

11. FOUNDATION LOADS: SEE NOTES ON " SITE CONDITIONS, SOILS, AND FOUNDATIONS".

12. FLOOR LIVE LOADS:  
 RESIDENTIAL ONE AND TWO STORY FAMILY DWELLINGS:  
 ALL LIVE LOADS PER TABLE R301.5  
 UNINHABITABLE ATTICS WITHOUT STORAGE : 10 PSF  
 UNINHABITABLE ATTICS WITH STORAGE : 20 PSI  
 HABITABLE ATTICS AND SLEEPING AREAS: 30 PSF  
 BALCONIES: 40 PSF  
 DECKS: 40 PSF  
 ALL OTHER ROOMS 40 PSF  
 GUARDRAILS /HANDRAILS :200PSF CONCENTRATED LOAD APPLIED IN ANY DIRECTION.

13. INFORMATION CONTAINED ON A PLAN SHEET WHERE HIS SIGNATURE AND SEAL APPEAR, THAT DOES NOT PERTAIN TO THE RELEVANT STRUCTURAL PROVISIONS AS STATED IN ITEM 4, INCLUDING, BUT NOT LIMITED TO THE BUILDING OCCUPANCY, THE ARCHITECTURAL DESIGN, ITS FEATURES, FINISHES (I.E. DECORATIVE STUCCO, SIDING, ROOFING, SOFFITS, FLASHING, PAINTING, ETC) AND THEIR INSTALLATION, DIMENSIONS, AND ANY DESIGN OF FIRE PROTECTION, ELECTRICAL, PLUMBING, AND MECHANICAL COMPONENTS OR SYSTEMS. THE ARCHITECTURAL INFORMATION, INCLUDING DIMENSIONS SHOWN IN THESE PLANS AND PROVIDED TO THE ENGINEER.

17. N/A

18. SITE PLAN AND TOPOGRAPHY

A. THE STRUCTURAL ENGINEER IS NOT A SURVEYOR AND IS NOT RESPONSIBLE FOR THE SITE PLAN, ESTABLISHING REQUIRED SET-BACKS, AND LOCATING THE BUILDING ON THE PROPERTY.

B. THE STRUCTURAL ENGINEER IS NOT RESPONSIBLE FOR THE GRADING OF THE SITE OR ITS COMPLIANCE WITH ANY DRAINAGE PLAN WHETHER INDIVIDUAL OR AS A PART OF A MASTER DRAINAGE PLAN.

C. THE FOUNDATION DESIGN IS BASED ON THESE PRESUMED CONDITIONS INCLUDING THAT DIFFERENTIAL SETTLING DOES NOT EXCEED THE SAFE LIMITS OF THE FOUNDATION DESIGN ( INCLUDING STEM WALLS AND MASONRY ABOVE GRADE WALLS) AS STATED IN ITEM 19 BELOW.

D. IT IS IMPORTANT TO KNOW THAT THE FOUNDATION DESIGN BASED ON A PRESUMED ALLOWABLE SOIL BEARING CAPACITY OF 2,000 PSF RELIES ON LESS THAN L/500 (E.G., 0.25 INCHES OVER 10 FEET ) OF DIFFERENTIAL SETTLEMENT. CRACKS IN MASONRY WALLS SHOULD BE EXPECTED WHERE DIFFERENTIAL SETTLEMENT EXCEEDS L/150. THIS STATEMENT SHOULD BE TAKEN AS A CAUTIONARY NOTE FOR PROCEEDING WITHOUT A SOILS ANALYSIS AND FOUNDATION RECOMMENDATION BY A GEOTECHNICAL ENGINEER FOR THE SITE.

E. COPIES OF ANY AND ALL REQUIRED COMPACTION TESTS ARE TO BE PROVIDED TO THE BUILDING DEPARTMENT FOR THEIR RECORDS.

**STRUCTURAL ELEMENTS**

19. FOUNDATION, FOOTING AND GROUND FLOOR SLAB

A. THE FOUNDATION AND FOOTINGS ARE TO BEAR A MINIMUM ON 12 INCHES BELOW GRADE AND ARE TO BE PLACED ON UNDISTURBED SOIL OR FILL COMPACTED TO A MINIMUM OF 95% MODIFIED PROCTOR PURSUANT TO ASTM D 1557 WITH FILL LIFTS LESS THAN 12".

**COMMERCIAL**

ALL LIVE LOADS PER FBC 2020 TABLE 1607.1

14. ROOF LIVE LOADS :  
 ALL ROOF / WOOD CONSTRUCTION TYPES ARE 30 PSF.

15. DEAD LOADS :  
 FLOOR WOOD FRAME : 35 PSF FOR TILE/MARBLE FLOOR COVERING, 15 PSF FOR ALL OTHERS.  
 ROOF WOOD FRAME : 25 PSF FOR SHINGLES, 35 PSF FOR TILE

16. WIND LOADS:  
 A. WIND LOADS ARE BASED ON THE SPECIFIC REQUIREMENTS AND DEFINITIONS OF FLORIDA RESIDENTIAL BUILDING CODE 2020 EDITION ASCE-7  
 B. THE COMPONENT AND CLADDING WIND PRESSURES ARE THE MINIMUM REQUIREMENTS FOR STRENGTH AND IMPACT PROTECTION NEEDED FOR SELECTING SATISFACTORY COMPONENTS AND CLADDING, BY OTHERS, FOR THE STRUCTURE.

ENGINEERING BY OTHERS IS PRESUMED ACCURATE AND IS RELIED UPON BY THE STRUCTURAL ENGINEER SOLEY FOR THE PURPOSE OF ACHIEVING COMPLIANCE WITH THE RELEVANT STRUCTURE

20. MIX DESIGNS FOR ALL CONCRETE USED IN THE CONSTRUCTION OF SLAB - ON - GRADE FLOORS SHALL SPECIFY A MINIMUM DESIGN STRENGTH OF 3,000 PSI (20.7 MPa ) AT 28 DAYS AND A DESIGN SLUMP NOT TO EXCEED 4 INCHES (102 mm ) . ON-SITE SLUMPS SHALL NOT EXCEED 5 INCHES (127mm) , PROVIDE TOTAL WATER ADDED TO THE MIX INCLUDING PLANT, TRANSIT AND SITE ADDED WATER DOES NOT EXCEED THE FOLLOWING PARAMETERS :

1. FOR MIXES USING NATURAL SANDS: 275 POUNDS PER CUBIC YARD ( 33 GALLONS- 125L )

2. FOR MIXES USING MANUFACTURED SANDS : 292 POUNDS PER CUBIC YARD (35 GALLONS -132L )

A. IN ADDITION, THE STRUCTURAL ENGINEER IS NOT A CIVIL OR GEOTECHNICAL ENGINEER AND IS NOT RESPONSIBLE FOR DETERMINING THE SUITABILITY OF THE SITE FOR CONSTRUCTION, INCLUDING ITS TOPOGRAPHY, DRAINAGE AND SUB-SURFACE CONDITIONS ( INCLUDING WATER TABLE DEPTH ) AND FOR INTERPRETING GEOTECHNICAL DATA CONCERNING THE SITE.

B. IF SOIL CONDITIONS AT THE SITE APPEAR QUESTIONABLE AS DETERMINED BY THE BUILDING CONTRACTOR OR OWNER-BUILDER, A SOILS ANALYSIS SHALL BE PERFORMED BY A LICENSED GEOTECHNICAL ENGINEER THAT WILL GIVE SPECIFIC RECOMMENDATIONS FOR A FOUNDATION TYPE. IF THE BUILDING CONTRACTOR OR OWNER-BUILDER DO NOT MAKE THAT DETERMINATION AND A SOILS ANALYSIS IS NOT PERFORMED, THE STRUCTURAL ENGINEER SHALL PROCEED WITH THE DESIGN BASED ON THE PRESUMPTIONS ALLOWED BY THE FBC 2020, SEC. 1804.

C. THE DETERMINATIONS OF THE SUITABILITY OF THE SITE FOR CONSTRUCTION ( INCLUDING TOPOGRAPHICAL INFORMATION ) AND THE SOIL CONDITIONS SHALL HAVE BEEN COMPLETED AND ANY RECOMMENDATIONS RESULTING FROM THAT ANALYSIS SHALL HAVE BEEN PROVIDED TO THE STRUCTURAL ENGINEER PRIOR TO THE SIGNING AND SEALING OF THE STRUCTURAL PLANS.

D. IN THE ABSENCE OF GEOTECHNICAL INFORMATION, THE SITE IS PRESUMED TO HAVE AN ALLOWABLE SOIL BEARING CAPACITY OF 2000 PSF AND THE TOPOGRAPHY AS IT RELATES TO THE STRUCTURE IS PRESUMED TO BE THAT SHOWN IN THE PLANS.

E. THE SIZE AND REQUIRED REINFORCEMENT FOR THE FOOTINGS ARE SHOWN ON THE FOUNDATION PLAN.  
 THE GROUND FLOOR SLAB SHALL BE PLACED OVER A 6 MIL. POLYETHYLENE MOISTURE RETARDER.

I. THE TRUSS SYSTEM DESIGN PROVIDED IN THIS PLAN IS FOR THE USE OF THE TRUSS MANUFACTURER IN DEVELOPING THE ACTUAL ROOF TRUSS SYSTEM DESIGN. IT IS NOT TO BE USED FOR ANY OTHER PURPOSE AS IT IS SUBJECT TO ENGINEERING AND MAY BE DIFFERENT FROM THE FINAL DESIGN.

II. MANUFACTURED FLOOR TRUSSES SHALL BE DESIGNED BY A LICENSED TRUSS COMPONENT AND TRUSS SYSTEM ENGINEER ACTING AS A DELEGATED ENGINEER AND WORKING THROUGH A TRUSS MANUFACTURER FOR THIS PURPOSE. THE SELECTION OF THE TRUSS MANUFACTURER IS HEREBY SUBORDINATED TO THE BUILDING CONTRACTOR.

III. THE MANUFACTURED TRUSS DESIGN SHALL INCLUDE SPECIFYING THE TRUSS TO TRUSS AND TRUSS TO GIRDER CONNECTIONS ON EITHER THE INDIVIDUAL TRUSS COMPONENT SHEETS OR THE GIRDER TRUSS COMPONENTS SHEETS AS APPLICABLE. A SPECIFIC HANGER MUST BE SELECTED AND IDENTIFIED ON THE SIGNED AND SEALED COMPONENT SHEETS FOR EACH LOCATION THAT A HANGER IS REQUIRED IN THE TRUSS SYSTEM.

IV. THE TRUSS PLAN SIGNED AND SEALED BY THE DELEGATED ENGINEER SHALL BE PROVIDED TO AND REVIEWED BY THE STRUCTURAL ENGINEER FOR COMPLYING WITH THE DESIGN INTENT OF THE ORIGINAL PLAN AND FOR ANY CHANGES TO THE " TRUSS TO UNDERLYING STRUCTURE" CONNECTIONS. THIS PLAN MUST BE PROVIDED TO THE STRUCTURAL ENGINEER PRIOR TO CONSTRUCTION ON THE UNDERLYING STRUCTURE AS THE STRUCTURAL ENGINEER RESERVES THE RIGHT TO MAKE STRUCTURAL CHANGES BASED UPON THE FINAL FLOOR TRUSS SYSTEM.

F. CONVENTIONAL FRAMED JOISTS WITH A MINIMUM 6 INCH OVERLAP OF JOINTS.

G. TERMITE TREATMENT OF THE SITE SHALL BE SPECIFIED BY THE BUILDING CONTRACTOR OR OWNER-BUILDER.

H. SHRINKAGE CONTROL OF THE FLOOR SLAB SHALL BE ACCOMPLISHED BY 6 INCH BY 6 INCH . W 1.4 BY 1.4 WELDED WIRE FABRIC AS SPECIFIED BY FBC 2020 SECTION 1907.2 EXCEPTION 2 OR FIBERMESH ADMIXTURE AS SPECIFIED BY FBC 2020, SECTION 1907.2 EXCEPT ON 1. THE WELDED WIRE FABRIC SHALL BE PLACED BETWEEN THE MIDDLE AND UPPER 1/3 DEPTH OF THE SLAB AND HELD IN POSITION BY APPROPRIATE SUPPORTS SPACED NOT GREATER THAN 3 FEET APART.

I. CONTRACTION JOINTS ARE TO BE PROVIDED FOR THE PURPOSE OF CONTROLLING SHRINKAGE. ONE INCH DEEP CUTS (FOR A FOUR INCH THICK SLAB OR 25 PERCENT OF THE SLAB THICKNESS OTHERWISE) ARE TO BE PROVIDED ACROSS THE WIDTH AND LENGTH OF ANY FLOOR SLAB AT A DISTANCE OF NOT TO EXCEED 30 TIMES THE SLAB THICKNESS. FOR EXAMPLE A FOUR INCH THICK SLAB, CONTRACTION JOINTS SHALL NOT EXCEED 10 FEET ON CENTER EACH WAY. THE CONTRACTION JOINTS ARE OPTIONAL FOR ONE AND TWO STORY FAMILY RESIDENTIAL WHEN WELDED WIRE FABRIC OR FIBERMESH ARE USED IN THE FLOOR SLAB.

**WINDCHESTER MODEL**

**A.E.C.S. 21019**

**STRUCTURAL ENGINEER NOTES**

ALLEN ENGINEERING & CONSTRUCTION SERVICES  
 RICH ALLEN PROFESSIONAL ENGINEER  
 P.E. # 56920 C.A. # 9542  
 P.O. BOX 351  
 NEW PORT RICHEY, FL. 34656  
 727-842-6100  
 richallenpe@gmail.com

HEREBY CERTIFY THAT I HAVE PERFORMED THE ATTACHED DESIGN TO COMPLY WITH 145 MPH ULTIMATE WIND LOADS AND IT IS IN COMPLIANCE WITH SECT. 301 OF THE 2020 FLORIDA RESIDENTIAL BUILDING CODE  
 SEALED FOR STRUCTURE ONLY  
 SIGNED: [Signature]  
 RICHARD E. ALLEN P.E. #56920

**BUILDING 63**  
 RESERVE AT HUNTERS RIDGE  
 PHASE THREE

**PLAN DATE**  
 02-24-2021

**DEEB FAMILY HOMES, LTD.**



21. FLOORS

A. MANUFACTURED FLOOR TRUSS FRAMING PLAN CONTAINED HEREIN IS FOR THE SOLE PURPOSE OF ILLUSTRATING THE DESIGN INTENT AND FOR PLANNING TO BE USED BY THE TRUSS COMPANY.

- I. FLOOR JOISTS ARE SIZED BASED ON THE SOUTHERN PINE COUNCIL SPAN TABLES FOR NO. 2 GRADE DIMENSIONAL LUMBER.
II. FLOOR JOISTS FOR EXTERIOR DECKS SHALL BE PRESSURE TREATED.
B. FOR ALL WOOD FLOORS:
I. THE TRUSS TO WALL CONNECTIONS ARE IDENTIFIED ON THE FLOOR FRAMING PLAN.
II. A STRUCTURAL BAND JOIST IS TO BE PROVIDED ON THE EXTERIOR PERIMETER OF ALL BOTTOM BEARING FLOOR TRUSSES AND JOISTS. THE STRUCTURAL BAND JOIST IS TO BE FASTENED TO EACH END OF A FLOOR TRUSS OR JOIST WITH A SIMPSON L50 BRACKET USING SIMPSON SHORT 10d COMMON NAILS.
III. FLOOR TRUSSES OR JOISTS BEARING ON WOOD WALLS ARE TO BE SET WITH A MINIMUM OF THREE 10d COMMON NAILS (TOE NAILED) TO THE TOP PLATE OF THE WALL.
IV. A MOISTURE BARRIER SHALL BE INSTALLED BETWEEN ANY UNTREATED WOOD TRUSSES OR JOISTS AND CONCRETE OR ANY MASONRY.
V. LEDGERS/ NAILERS SHALL BE FASTENED TO WOOD STUDS OR BAND JOISTS (NOT SHEATHING) WITH A MINIMUM 2 3/8" X 5 1/2" LAG BOLTS WITH WASHERS AT EACH STUD INTERSECTION AT 16 INCHES ON CENTER AND SHALL CONSIST OF PRESSURE TREATED LUMBER 2 PLY 1 1/2" THICK BY A HEIGHT SHOWN IN THE PLANS. FOR CONCRETE OR MASONRY WALLS THE FASTENERS SHALL BE 5/8" X 5 1/2" SIMPSON TITEN HEAD CONCRETE BOLTS.
VI. FLOOR BEAMS
I. BEAMS SUPPORTING FLOOR TRUSSES AND JOISTS ARE TO BE ATTACHED AS SPECIFIED IN THE FLOOR FRAMING PLAN. UNDER NO CIRCUMSTANCES ARE THERE TO BE BUTT JOINTS BETWEEN THE BEARING POINTS OF ANY PLY OF A MULTIPLE BEAM. THE PLIES ARE TO BE CONTINUOUS BETWEEN BEARING POINTS.
II. MULTIPLE BEAMS CONSISTING OF MANUFACTURED WOOD (I.E. GLULAM, MICROLAM) ARE TO HAVE THE INDIVIDUAL PLIES INTERCONNECTED AS REQUIRED BY THE MANUFACTURERS SPECIFICATIONS.
III. MULTIPLE BEAMS CONSISTING OF DIMENSIONAL LUMBER ARE TO HAVE INDIVIDUAL PLIES INTERCONNECTED AS FOLLOWS:
A. FOR TWO PLY BEAMS- ONE ROW OF 10d GALVANIZED COMMON NAILS AT 6" O.C. ON EACH SIDE OF THE BEAM
B. FOR THREE PLY BEAMS- TWO ROWS OF 16d GALVANIZED COMMON NAILS SPACED AT 6" O.C. (TOP AND BOTTOM) THRU EACH SIDE OF BEAM.
C. FOR FOUR PLY BEAMS OR LARGER-TWO ROWS OF 1/2" DIAMETER CARRIAGE BOLTS OR ALL THREAD ROD WITH NUTS AND WASHERS SPACED AT 12 INCHES ON CENTER, 2 INCHES FROM THE TOP AND BOTTOM EDGES OF THE BEAM.
D. FLOOR SHEATHING:
I. ALL FLOOR SHEATHING IS TO BE 3/4" TONGUE AND GROOVE PLYWOOD RATED FOR FLOOR SHEATHING APPLICATION.
II. FLOOR SHEATHING SHALL BE FASTENED TO THE FLOOR TRUSSES /JOISTS WITH 16d RING SHANK NAILS AT 6" ON CENTER WITH CONSTRUCTION GRADE ADHESIVE.
III. FLOOR SHEATHING SPECIFIED FOR SEALED EXTERIOR DECKS AND ITS INSTALLATION SHALL BE THE SAME AS THAT FOR INTERIOR APPLICATION EXCEPT PRESSURE TREATED AND THE FASTENERS TO BE GALVANIZED.
E. EXTERIOR DECK FLOORING:
I. DECK FLOORING SHALL BE INDIVIDUALLY SPECIFIED ON THE FLOOR FRAMING PLANS AND SHALL BE FASTENED TO THE UNDERLYING PRESSURE TREATED JOISTS WITH 3- 3 INCH DECK SCREWS AT EACH FLOORING JOIST INTERSECTION.

22. WALLS:

- A. MASONRY
I. CONCRETE MASONRY UNITS (CMU) SHALL HAVE A MINIMUM COMPRESSIVE STRENGTH OF 1900 PSI.
II. WALL CMU SHALL BE 8 INCH X 16 INCH IN SIZE OR 8 INCH X 8 INCH X 8 INCH FOR EDGE FINISHES.
III. CMU SHALL BE PLACED IN A RUNNING BOND AND THERE SHALL BE NO VERTICAL BUTT JOINTS EXCEPT AS SHOWN ON THE FLOOR PLAN FOR CONSTRUCTION JOINTS.
IV. REINFORCED FILLED CELLS AS SHOWN ON THE PLANS SHALL BE FILLED WITH " FINE" GRADE GROUT, HAVE A MINIMUM COMPRESSIVE STRENGTH OF 3,000 PSI AND 8 TO 11 INCH SLUMP TO ENSURE CONSOLIDATION.
V. BOND BEAMS SHALL BE POURED WITH GROUT MONOLITHICALLY WITH THE FILLED WALL CELLS-NO COLD JOINTS.
VI. VERTICAL STEEL REINFORCEMENT SHALL BE CONTINUOUS BETWEEN THE MIDDLE AND BOTTOM 1/3 OF THE FOOTING HEIGHT AND END IN THE TOP COURSE OF THE BOND BEAM WITH A STANDARD 10 INCH 90 DEGREE BEND.
VII. HORIZONTAL REINFORCING STEEL SHALL BE CONTINUOUS, INCLUDING AROUND CORNERS.
VIII. REINFORCING STEEL SPLICES SHALL CONSIST OF WIRE LAPS NO LESS THAN 40 TIMES THE STEEL BAR DIAMETER (I.E. 25 INCHES FOR #5 REBAR, 15 INCHES FOR #3 REBAR, AND 52 INCHES FOR #7 REBAR)
B. WOOD FRAME WALLS:
I. WALL STUD SIZES ARE SHOWN IN THE TYPICAL WALL SECTION.
II. LOAD BEARING.
1. WOOD STUDS IN WALLS SHALL BE SPACED 16 INCHES ON CENTER AND FASTENED TO THE TOP AND BOTTOM PLATES PER THE TOP PLATE SPlice DETAIL. ALL LOAD BEARING STUDS TO BE SOUTHERN YELLOW PINE #2 GRADE OR BETTER.
2. LOAD BEARING WALLS SHALL HAVE A SINGLE BOTTOM PLATE (PRESSURE TREATED) IN CONTACT WITH MASONRY OR CONCRETE. SEE THE TOP PLATE SPICE DETAIL FOR TOP PLATE NAILING AND SPLICING REQUIREMENTS.
3. THE WOOD STUDS SHALL HAVE A SIMPSON SP2 AT THE TOP PLATE AND A PROPERLY SIZED SPH FOR THE BOTTOM PLATE (I.E. 4" STUD WALL = SPH4, 6" STUD WALL = SPH6)
4. 3 STUD PACK SHALL BE INSTALLED DIRECTLY BENEATH BEARING POINTS OF ALL GIRDERS AND BEAMS HAVING A GRAVITY LOAD OF UP TO 3,000 LBS.
5. STEEL TUBE COLUMNS SHALL BE INSTALLED IN THE WALL DIRECTLY BENEATH GIRDERS AND BEAMS HAVING GRAVITY LOADS GREATER THAN 3000 LBS.
6. BASE PLATES SHALL BE FASTENED TO MONOLITHIC FOOTINGS WITH 5/8" X 8 INCH ANCHOR BOLTS OR SIMPSON TITEN HD. CONCRETE BOLTS OF THE SAME SIZE AT 24 INCHES ON CENTER. ALL CONNECTIONS SHALL BE MADE WITH 3 INCH SQUARE BY 1/8 INCH THICK WASHERS
7. BASE PLATES BEARING ON WOOD SHALL BE FASTENED WITH 16d COMMON NAILS AT 8" O.C. THROUGH ANY FLOOR SHEATHING AND TO UNDERLYING LUMBER (NOT SHEATHING ONLY) AND USE BLOCKING AS NEEDED TO MAINTAIN NAILING SPACING REQUIREMENTS.
8. FOR EXTERIOR LOAD BEARING WALLS, EACH STUD ABOVE THE BASE PLATE SHALL BE FASTENED TO THE UNDERLYING BAND JOIST OR BEAM WITH A SIMPSON LSTA18 STRAP. FOR THIS SITUATION THE SIMPSON SPH BRACKET TO THE BASE PLAN MAY BE OMITTED.
9. FOR INTERIOR LOAD BEARING WALLS, 1/2 INCH ALL THREAD ROD SHALL BE INSTALLED AT 32" O.C. FROM THE BASE PLATE THROUGH THE SHEATHING AND TOP PLATE OF UNDERLYING SUPPORTING WALL. ALL CONNECTIONS SHALL INCLUDE A STANDARD 3 INCH SQUARE WASHER.
10. HEADER BEAMS SHALL BE SIZED ACCORDING TO THE ENCLOSED HEADER SCHEDULE AND FASTENED WITH A MINIMUM OF TWO SIMPSON LSTA36 STRAPS OVER EACH END TO THE JACK STUDS BELOW. IN ADDITION, THE HEADER BEAMS SHALL BE FASTENED WITH A MINIMUM OF 3-10d COMMON NAILS ( TOE NAILED ON EACH FACE SIDE AT EACH END TO THE ABUTTING FULL LENGTH STUDS ).
III. NON LOAD BEARING WALLS:
1. WOOD STUDS IN WALLS SHALL BE SPACED AT 16 INCHES ON CENTER AND FASTENED TO THE TOP AND BOTTOM PLATES WITH A MINIMUM OF THREE 10d COMMON NAILS. NAILS INSTALLED IN PRESSURE TREATED WOOD SHALL BE GALVANIZED.
2. INCIDENTAL, NON STRUCTURAL FRAMING ITEMS SUCH AS KNEE WALLS, DROP CEILINGS, BUILT IN SHELVING, NICHES, ETC. MAY BE CONSTRUCTED WITH 2 X 4'S AT 24" O.C. AT THE DISCRETION OF THE BUILDER.

- 2. NON LOAD BEARING WALLS SHALL HAVE A SINGLE BOTTOM PLATE (PRESSURE TREATED AGAINST MASONRY AND CONCRETE ) AND A SINGLE TOP PLATE.
3. BASE PLATES SHALL BE FASTENED TO CONCRETE SLABS WITH 1/4 INCH BY 3 1/2 INCH TAPCON SCREWS AT 12 " ON CENTER.
4. BASE PLATES ON WOOD SHALL BE FASTENED WITH 16d COMMON NAILS AT 8" ON CENTER.

- C. SHEATHING
I. PLYWOOD SHEATHING.
1. EXTERIOR WALL SHEATHING COVERED BY AN ARCHITECTURAL FINISH SHALL BE MINIMUM 7/16 INCH THICK (NOMINAL ) 4 PLY PLYWOOD MANUFACTURED WITH EXTERIOR GLUE.
2. THE LONG SIDE OF THE SHEATHING SHALL BE INSTALLED PERPENDICULAR TO THE WALL STUDS.
3. FASTEN TO STUDS AND BLOCKING WITH 8d RING SHANK NAILS AT 4 INCHES ON CENTER ALL LOCATIONS.
4. IN ADDITION TO THE REGULAR FASTENING, A SECOND ROW SHALL BE INSTALLED AT THE DOUBLE TOP PLATE AND TO THE LOWEST HORIZONTAL WOOD MEMBER ON AN EXTERIOR WALL. (I.E. SILL PLATE, BAND JOIST)
5. FOR PLYWOOD SHEATHING COVERED WITH A CEMENTITIOUS FINISH ALL BUTT JOINTS NOT ON WALL STUDS SHALL BE BLOCKED WITH 2 X BLOCKING, TOE NAILED AT EACH END TO THE WALL STUDS WITH 3-8d COMMON NAILS.
II. PARTICLE BOARD
1. PARTICLE BOARD IS NOT TO BE USED WITHOUT THE EXPRESS, WRITTEN CONSENT OF THE STRUCTURAL ENGINEER AND THE PROPERTY OWNER.

- III. ARCHITECTURAL FINISHES
1. ARCHITECTURAL WALL FINISHES, SUCH AS STUCCO, CEMENTITIOUS COATING, SIDING OR PAINT ARE MENTIONED HERE ONLY FOR THE PURPOSE OF UNDERSTANDING THAT THEIR INSTALLATION AND ASSOCIATED DETAILS ARE NOT THE RESPONSIBILITY OF THE STRUCTURAL ENGINEER.

- 23. COLUMNS
A. CONCRETE /MASONRY COLUMNS
1. MASONRY COLUMNS SHALL BE CONSTRUCTED OF PILASTER CONCRETE BLOCK OR FORMED AND POURED. WALL BLOCK SHALL NOT BE USED FOR MASONRY COLUMNS.
II. REINFORCING STEEL SHALL BE GRADE 60 AND HELD IN PLACE BY STIRUPS SPACED AT 12 INCHES ON CENTER VERTICALLY.
III. PILASTER BLOCK COLUMNS SHALL BE FILLED WITH A FINE GROUT HAVING A MINIMUM COMPRESSIVE STRENGTH OF 3,000 PSI
IV. FORMED AND POURED COLUMNS SHALL CONSIST OF A MINIMUM OF 3,000 PSI CONCRETE, OR IN AREAS OF HIGH CHLORIDES, SUCH AS NEAR THE COAST OR BODIES OF SALT WATER, THE MINIMUM SHALL BE 5,000 PSI
V. ALL MASONRY COLUMNS SHALL BEGIN AT THE FOUNDATION OR AT A MONOLITHIC FOOTING, IN NO CASE SHALL THERE BE A BREAK OR A COLD JOINT IN THE GROUT OF A COLUMN EXCEPT AT 1 FOOT FROM THE TOP IN PREPARATION FOR INSTALLATION OF A CONCRETE LINTEL.
VI. METAL CONNECTORS AT THE TOP OF THE COLUMN FOR HOLDING WOOD BEAMS OR GIRDERS SHALL BE INSTALLED WITH THE MINIMUM EMBEDMENT OF THE ASSOCIATED FASTENERS FOR THE CONNECTOR AS SHOWN ON THE PLANS.

- B. WOOD COLUMNS:
I. ALL LOAD BEARING WOOD COLUMNS SHALL BE A MINIMUM OF #2 GRADE PRESSURE TREATED WOOD.
II. DIMENSIONAL WOOD COLUMNS OF 4 INCHES BY 4 INCHES IN CROSS SECTION SHALL ONLY BE USED FOR SUPPORTING OPEN WOOD DECKS WHERE THE FLOOR HEIGHT ABOVE THE FLOOR BELOW IS 8 FEET OR LESS. ALL OTHER DIMENSIONAL WOOD COLUMNS SHALL HAVE A MINIMUM OF 6 INCHES BY 6 INCHES.
III. METAL CONNECTORS AT THE BASE AND THE TOP OF WOOD COLUMNS SHALL BE OF THE TYPE THAT RESISTS LATERAL LOADS AS WELL AS UPLIFT AND GRAVITY LOADS. IN NO CASE SHALL FLAT STRAPS BE USED UNLESS SPECIFICALLY SHOWN IN THE PLANS OR CROSS SECTION DETAIL.S.

STRUCTURAL ENGINEER NOTES A.E.C.S. 21019 WINDCHESTER MODEL
DEEB FAMILY HOMES, LTD.
PLAN DATE 02-24-2021
BUILDING 63 RESERVE AT HUNTERS RIDGE PHASE THREE
ALLEN ENGINEERING & CONSTRUCTION SERVICES
RICH ALLEN PROFESSIONAL ENGINEER
P.E. # 56920 C.A. # 9542
RICH ALLEN
P.E. # 56920



C. COMPOSITE COLUMNS

- I. A COMPOSITE COLUMN HERE IS DEFINED AS A HOLLOW COLUMN CONSISTING OF ANY MATERIAL SPECIFICALLY DESIGNED BY ITS MANUFACTURER TO BE LOAD BEARING. ANY OTHER TYPE OF HOLLOW COLUMN IS CONSIDERED AN ARCHITECTURAL FINISH INTENDED TO FIT OVER A STRUCTURAL COLUMN AND ITS USE AND DETAILS OF INSTALLATION ARE NOT THE RESPONSIBILITY OF THE STRUCTURAL ENGINEER.
- II. LOAD BEARING COMPOSITE COLUMNS ARE A MANUFACTURED PRODUCT SUBJECT TO THE DESIGN AND LOAD BEARING CAPACITY AS DETERMINED BY THE MANUFACTURER. A SHOP DRAWING OR A LETTER FOR THE INSTALLATION OF THE COLUMN SHALL BE PROVIDED BY THE STRUCTURAL ENGINEER TO SUPPLEMENT THE CONSTRUCTION PLANS AFTER THE SPECIFIC COLUMN AND MANUFACTURER HAVE BEEN IDENTIFIED.
- III. IN ALL CASES, THE COLUMN MANUFACTURER'S INFORMATION SHALL BE PROVIDED TO THE STRUCTURAL ENGINEER BY THE CONTRACTING CLIENT OR HIS AGENT FOR REVIEW PRIOR TO ITS ACCEPTANCE FOR THE STRUCTURAL DESIGN. THE INFORMATION SHALL INCLUDE THE LATERAL AS WELL AS UPLIFT AND GRAVITY LOAD BEARING CAPACITIES.
- D. STEEL TUBE COLUMNS:
  - I. LOAD BEARING STEEL TUBE COLUMNS SHALL HAVE A MINIMUM WALL THICKNESS OF 1/4 INCH AND BE MADE OF STEEL WITH A DESIGN YIELD STRENGTH OF 46 PSI UNLESS OTHERWISE SHOWN IN THE STRUCTURAL DESIGN
  - II. THE SPECIFIC CONNECTION SCHEME SHALL BE SHOWN IN THE STRUCTURAL DESIGN WHERE THE STEEL TUBE COLUMN IS TO BE INSTALLED.

E. ALUMINUM COLUMNS:

- I. LOAD BEARING ALUMINUM COLUMNS SHALL HAVE A MINIMUM WALL THICKNESS OF 1/4 INCH.
- II. ALL FASTENERS AND CONNECTORS FOR ALUMINUM COLUMNS SHALL BE STAINLESS STEEL TO AVOID CORROSION DUE TO DISSIMILAR METALS BEING IN CONTACT.
- III. THE SPECIFIC CONNECTION SCHEME SHALL BE SHOWN IN THE STRUCTURAL DESIGN WHERE THE ALUMINUM COLUMN IS TO BE INSTALLED.

24. ROOF

A. MANUFACTURED WOOD TRUSSES

- I. THE MANUFACTURED ROOF TRUSS FRAMING PLAN CONTAINED HEREIN IS FOR THE SOLE PURPOSE OF ILLUSTRATING THE DESIGN INTENT AND FOR PLANNING TO BE USED BY THE TRUSS COMPONENT AND TRUSS SYSTEM ENGINEER OF THE TRUSS MANUFACTURER IN DEVELOPING THE ACTUAL SYSTEM DESIGN. IT IS NOT INTENDED TO BE USED FOR ANY OTHER PURPOSE AS IT IS SUBJECT TO ENGINEERING AND MAY BE DIFFERENT FROM THE FINAL DESIGN.
  - II. MANUFACTURED ROOF TRUSSES SHALL BE DESIGNED BY A LICENSED TRUSS COMPONENT AND TRUSS SYSTEM ENGINEER ACTING AS A DELEGATED ENGINEER AND WORKING THROUGH A TRUSS MANUFACTURER FOR THIS PURPOSE. THE SELECTION OF THE TRUSS MANUFACTURER IS HEREBY SUBORDINATED TO THE BUILDING CONTRACTOR.
  - III. THE TRUSS PLAN "SIGNED AND SEALED" BY THE DELEGATED ENGINEER SHALL BE PROVIDED TO AND PRIOR TO CONSTRUCTION OF THE UNDERLYING STRUCTURE AS THE STRUCTURAL ENGINEER RESERVES THE RIGHT TO MAKE STRUCTURAL CHANGES BASED ON THE FINAL FLOOR TRUSS SYSTEM.
  - VI. THE TRUSS MANUFACTURER SHALL PROVIDE ALL LATERAL BRACING REQUIREMENTS TO THE BUILDING CONTRACTOR. IF NOT, THE BUILDING CONTRACTOR IS TO NOTIFY THE STRUCTURAL ENGINEER FOR GUIDANCE.
  - V. IN ADDITION TO THE METAL CONNECTORS SHOWN IN THE TRUSS LAYOUT OF THE ORIGINAL PLANS, EACH TRUSS IS TO BE SET ON WOOD FRAME BEARING WALLS OR SILL PLATES WITH 10d COMMON NAILS (TOE-NAILED)
  - VI. A MOISTURE BARRIER IS TO BE INSTALLED BETWEEN UNTREATED WOOD AND CONCRETE / MASONRY
- 23.2 CONVENTIONAL FRAME
- I. IN ADDITION TO THE METAL CONNECTORS SHOWN IN THE TRUSS LAYOUT OF THE ORIGINAL PLANS, EACH RAFTER IS TO BE SET ON WOOD FRAME BEARING WALLS OR SILL PLATES WITH 3- 10d COMMON NAILS (TOE-NAILED)
  - II. ANY WOOD COMING IN CONTACT WITH MASONRY OR CONCRETE IS TO BE PRESSURE TREATED OR A MOISTURE BARRIER IS TO BE INSTALLED BETWEEN UNTREATED WOOD AND CONCRETE OR MASONRY.

- III. COLLAR TIES ARE TO BE INSTALLED BETWEEN RAFTERS AT 2/3 OF THE RIDGE HEIGHT FROM WHERE THE RAFTERS BEAR ON WALLS. THE COLLAR TIES ARE TO BE FASTENED WITH A MINIMUM OF 4-10d 16 COMMON NAILS (CLINCHED) AT EACH LAP JOINT. EACH RAFTER IS TO BE ATTACHED TO THE RIDGE BEAM WITH A LIGHT ANGLE HANGER AS SHOWN IN THE FRAMING PLAN. IN ADDITION, A FLAT METAL STRAP SHALL BE INSTALLED ACROSS THE RIDGE BEAM TO TWO OPPOSING RAFTERS. TO BE REVIEWED BY THE STRUCTURAL ENGINEER FOR COMPLYING WITH THE DESIGN INTENT OF THE ORIGINAL PLAN AND FOR ANY CHANGES TO THE "TRUSS TO THE UNDERLYING STRUCTURE" CONNECTIONS.
  - IV. AS PART OF THE REVIEW, THE STRUCTURAL ENGINEER WILL DETERMINE WHETHER THE TRUSS TO WALL / BEAM METAL CONNECTORS SHOWN IN THE ORIGINAL PLANS ARE ACCEPTABLE OR WHETHER THEY NEED TO BE CHANGED OR SUPPLEMENTED TO ACCOMMODATE THE LOADS SHOWN IN THE TRUSS COMPONENT SHEETS.
  - V. THE STRUCTURAL ENGINEER IS NOT RESPONSIBLE FOR VERIFYING THE DIMENSIONAL, ARCHITECTURAL, OR FORM ASPECTS OF THE OF THE TRUSS MANUFACTURERS PLAN WITH THE ORIGINAL PLANS.
  - VI. THE MINIMUM LIVE LOADS FOR THE ROOF TRUSS DESIGN IS TO BE ON FBC 2020 SECTION 1607 FOR ROOF TYPE AND ROOFING MATERIAL.
  - VII. THE DEAD LOADS ARE LISTED IN ITEM 16 ABOVE.
  - VIII. ALL TRUSS TO TRUSS AND TRUSS TO GIRDER CONNECTORS ARE TO BE SPECIFIED BY THE TRUSS MANUFACTURER, INCLUDING CONNECTORS FOR TRUSS TO MANUFACTURED BEAM (I.E. GLUELAM, OR MICROLAM) SPECIFIED BY THE TRUSS MANUFACTURER. A SPECIFIC HANGER MUST BE SELECTED AND IDENTIFIED ON THE SIGNED AND SEALED COMPONENT SHEETS FOR EACH LOCATION, A HANGER IS REQUIRED IN THE TRUSS SYSTEM.
  - IX. THE TRUSS PLAN SIGNED AND SEALED BY THE DELEGATED ENGINEER SHALL BE PROVIDED TO AND REVIEWED BY THE STRUCTURAL ENGINEER FOR COMPLYING WITH THE DESIGN INTENT OF THE ORIGINAL PLAN AND FOR ANY CHANGES TO THE "TRUSS TO UNDERLYING STRUCTURE" CONNECTIONS. THIS PLAN MUST BE PROVIDED TO THE STRUCTURAL ENGINEER.
  - X. A RIDGE BEAM TERMINATING AT A GABLE END SHALL BE SUPPORTED BY A MINIMUM 3 STUD PACK COLUMN BEARING ON THE UNDERLYING WALL OR BEAM.
  - XI. TREATED LUMBER-DOUBLE 1 1/2 INCH BY A HEIGHT SHOWN ON THE PLANS. FOR CONCRETE OR MASONRY WALLS THE FASTENERS SHALL BE 5/8 INCH BY 5 1/2 INCH SIMPSON TITEN HD CONCRETE BOLTS.
  - XII. SLEEPERS SHALL BE FASTENED TO UNDERLYING ROOF TRUSSES OR RAFTERS (NOT SHEATHING) WITH A MINIMUM OF 2-3/8 INCH BY 3 1/2 INCH LAG BOLTS AND WASHERS AT EACH TRUSS OR RAFTER INTERSECTION AND NO GREATER THAN 24 INCHES ON CENTER AND SHALL CONSIST OF DIMENSIONAL LUMBER 1 1/2 INCH THICK BY A WIDTH SHOWN IN THE PLANS
  - XIII. USE 2 INCH BY 4 INCH BLOCKING ATTACHED BETWEEN UNDERLYING STUDS, TRUSSES OR RAFTERS WITH A MINIMUM OF 3-10d NAILS AT EACH IN ORDER TO SATISFY THE ON CENTER SPACING FOR THE LEDGERS OR SLEEPERS.
  - XIV. BEAMS SUPPORTING ROOF TRUSSES OR RAFTERS ARE TO BE ATTACHED AS SPECIFIED IN THE ROOF FRAMING PLANS.
24. UNDER NO CIRCUMSTANCES ARE THERE TO BE BUTT JOINTS BETWEEN THE BEARING POINTS OF ANY PLY OF A MULTIPLE BEAM. THE PLYS ARE TO BE CONTINUOUS BETWEEN BEARING POINTS.
- A. LEDGERS/ SLEEPERS
  - I. LEDGERS / NAILERS SHALL BE FASTENED TO WOOD STUDS (NOT SHEATHING) WITH A MINIMUM OF 2- 3/8 INCH BY 5 1/2 INCH LAG BOLTS WITH WASHERS AT EACH STUD INTERSECTION AND NO GREATER THAN 16 INCHES ON CENTER AND SHALL CONSIST ON PRESSURE TREATED WOOD.
  - II. MULTIPLE BEAMS CONSISTING OF MANUFACTURED WOOD (I.E. GLUELAM, MICROLAM) ARE TO HAVE THE INDIVIDUAL PLYS INTERCONNECTED AS REQUIRED BY THE MANUFACTURERS SPECIFICATIONS.

- III. MULTIPLE BEAMS CONSISTING OF DIMENSIONAL LUMBER ARE TO HAVE THE INDIVIDUAL PLYS INTERCONNECTED AS FOLLOWS:
  - I. FOR TWO PLY BEAMS - ONE ROW OF 10d GALVANIZED COMMON NAILS AT 6 INCHES ON CENTER ON EACH SIDE OF BEAM.
  - II. FOR THREE PLY BEAMS- TWO ROWS OF 16d GALVANIZED COMMON NAILS AT 6" ON CENTER (TOP AND BOTTOM) THRU EACH SIDE OF THE BEAM.
  - III. FOR FOUR PLY BEAMS AND LARGER- TWO ROWS OF 1/2 INCH DIAMETER CARRIAGE BOLTS OR ALL THREAD RODS WITH NUTS AND WASHERS SPACED AT 12" ON CENTER 2 INCHES FROM THE TOP AND BOTTOM EDGES OF THE BEAM.
- B. SHEATHING :
  - I. ROOF SHEATHING COVERED BY COMPOSITE ROOFING SHALL BE A MINIMUM OF 15/32 INCH THICK (NOMINAL ) O.S.B. MANUFACTURED WITH EXTERIOR GLUE.
  - II. ROOF SHEATHING COVERED BY TILE SHALL BE A MINIMUM OF 5/8 INCH THICK (NOMINAL ) MANUFACTURED WITH EXTERIOR GLUE, 19/32 INCH FOR EXPOSURE C + D
  - III. THE LONG SIDE OF THE SHEATHING SHALL BE INSTALLED PERPENDICULAR TO THE ROOF TRUSS SYSTEM.
  - IV. FASTENING SHALL BE 8d RING SHANK NAILS AT 4 INCHES ON CENTER AT BOUNDARY AND EDGES AND 6 INCHES ON CENTER IN THE FIELD WITH A SETBACK OF 4'-0" FROM ALL EDGES, 10 d + 4" O.C. ALL LOCATIONS EXCEPT EXPOSURE C + D
  - V. METAL "H" CLIPS OR SOLID WOOD BLOCKING SHALL BE USED AT ALL UNSUPPORTED BUTT JOINTS BETWEEN TRUSSES OR RAFTERS.
25. PRECAST CONCRETE LINTELS
  - A. PRECAST AND PRESTRESSED CONCRETE LINTELS SHALL BE MANUFACTURED BY CASTCRETE AND INSTALLED PER MANUFACTURES SPECIFICATIONS AND INSTRUCTIONS.
  - B. THE SIZE OF THE LINTELS SHALL BE BASED ON THE SPAN AND LOAD. REFER TO THE ATTACHED SCHEDULE UNLESS OTHERWISE SHOWN IN THE STRUCTURAL DESIGN FOR THE SPECIFIED LINTEL
  - C. LINTEL SCHEDULE U.N.O. ON PLANS:
    - I. SPAN UP TO 3'- 8F8-0B
    - II. SPAN UP TO 3' TO < 6' - 8F8-0B
    - III. SPAN 6' TO > 14' - 8F16- 1B 1T
  - D. THE MINIMUM SPECIFIED GROUT COMPRESSIVE STRENGTH TO BE USED FOR LINTELS IS 3,000 PSI.
  - E. THE REINFORCING STEEL SHALL BE ASTM GRADE 60
26. FASTENERS / METAL CONNECTORS.
  - A. ALL FASTENERS AND METAL CONNECTORS SHALL BE MANUFACTURED BY SIMPSON STRONG TIE AND INSTALLED PER THE MANUFACTURES SPECIFICATIONS AND INSTRUCTIONS.
  - B. THESE FASTENERS DO NOT INCLUDE TYPICAL NAILS AND SCREWS WHICH MAY BE MANUFACTURED BY OTHERS.
  - C. FOLLOW ALL MANUFACTURES SPECIFICATIONS AND INSTRUCTIONS FOR ALL FASTENERS, METAL CONNECTIONS, SCREWS, NAILS, ETC. THAT ARE IN CONTACT WITH PRESSURE TREATED LUMBER.
27. DIMENSIONAL LUMBER :
  - A. ALL LOAD BEARING WALLS SHALL BE SOUTHERN YELLOW PINE #2 OR BETTER GRADED AND STAMPED BY THE CERTIFYING AGENCY. IN ADDITION, ALL WOOD SHALL BE PRESSURE TREATED FOR EXTERIOR USE WHERE EXPOSED TO MOISTURE, PLACED WITHIN 12 INCHES OF SOIL OR IN CONTACT WITH CONCRETE OR MASONRY.
28. STRUCTURAL SHEATHING:
  - A. ALL SHEATHING USED FOR EXTERIOR APPLICATIONS SHALL BE EXTERIOR GRADE AND ADA STAMPED AND VERIFYING ITS RATING.
29. MASONRY:
  - A. CONCRETE MASONRY UNITS SHALL CONFORM WITH AMERICAN MASONRY INSTITUTE STANDARD 530
  - B. CONCRETE MASONRY UNITS SHALL HAVE A MINIMUM COMPRESSIVE STRENGTH OF 1900 PSI
  - C. MORTAR SHALL BE OF TYPE M OR S GRAY MORTAR.
30. GROUT:
  - A. ALL GROUT SHALL BE A FINE TYPE HAVING A MINIMUM COMPRESSIVE STRENGTH OF 3,000 PSI UNLESS SPECIFICALLY SHOWN OTHERWISE BY A MANUFACTURER PURSUANT TO GROUT USE WITH ITS PRODUCTS.
31. REINFORCING STEEL :
  - A. ALL REINFORCING STEEL SHALL BE ASTM GRADE 40 EXCEPT GRADE 60 SHALL BE USED FOR GRADE BEAMS, ALL LINTEL TYPES (I.E. PRECAST AND FIELD PREFORMED ) COLUMNS UNLESS OTHERWISE SHOWN IN THE STRUCTURAL PLANS.

STRUCTURAL ENGINEER NOTES

A.E.C.S. 21019

WINDCHESTER MODEL



DEEB FAMILY HOMES, LTD.

PLAN DATE

02-24-2021

BUILDING 63  
RESERVE AT HUNTERS RIDGE  
PHASE THREE

HEREBY CERTIFY THAT I HAVE PERFORMED THE ATTACHED DESIGN TO COMPLY WITH 1-45 MPH ULTIMATE WIND LOADS AND IT IS IN COMPLIANCE WITH SECT. 301 OF THE 2020 FLORIDA RESIDENTIAL BUILDING CODE  
SEALED FOR STRUCTURE ONLY  
SIGNED: [Signature] P.E. #56920  
RICHARD E. ALLEN

ALLEN ENGINEERING & CONSTRUCTION SERVICES  
RICH ALLEN PROFESSIONAL ENGINEER  
P.E. #56920 C.A. # 9542  
P.O. BOX 351  
NEW PORT RICHEY, FL. 34666  
727-842-6100  
richallenpe@gmail.com

32. STRUCTURAL STEEL AND CONNECTION ACCESSORY MATERIAL:
- A. I-BEAMS, FORMED STRUCTURAL STEEL, FLAT BAR OR PLATE SHALL BE ASTM GRADE A36 UNLESS STATED OTHERWISE.
  - B. ALL STRUCTURAL STEEL SHALL HAVE A MINIMUM OF TWO COATS OF PRIMER AND TWO COATS OF EPOXY AS A CORROSION PREVENTIVE. THE BUILDING CONTRACTOR MAY VARY FROM THIS SPECIFICATION WITH THE APPROVAL OF THE STRUCTURAL ENGINEER IF IT CAN BE DEMONSTRATED ANOTHER MEANS OF CORROSION CONTROL IS EQUALLY EFFECTIVE.
  - C. ALL WELDING OF STRUCTURAL STEEL SHALL BE MADE WITH E6070 TYPE ELECTRODES. THE DEPTH AND LENGTH FOR THE WELD SHALL BE SPECIFIED IN THE STRUCTURAL DESIGN FOR THE SPECIFIC CONNECTION.
33. VENTILATION:
- A. THE STRUCTURAL ENGINEER IS NOT RESPONSIBLE FOR DETERMINING VENTILATION REQUIREMENTS OF CRAWL SPACES, FLOORS AND ATTICS NOR THE MEANS AND METHODS FOR IMPLEMENTING THESE REQUIREMENTS.
34. WATERPROOFING:
- A. ANY RENDERING OF NOTES OF WATERPROOFING MEASURES FOR BASEMENTS OR HALF BASEMENTS SHOWN IN THESE PLANS WHERE A SPECIFIC CONSTRUCTION DETAIL IS NOT SHOWN IN THE STRUCTURAL DESIGN IS AN ARCHITECTURAL ILLUSTRATION ONLY AND IS NOT PART OF THE STRUCTURAL DESIGN OR THE RESPONSIBILITY OF THE STRUCTURAL ENGINEER.
  - B. CRICKETS ARE ASSOCIATED WITH THE ARCHITECTURAL FINISHES AND ARE NOT THE RESPONSIBILITY OF THE STRUCTURAL ENGINEER.
35. FIRE RESISTANT DESIGN:
- A. FIRE RESISTANT DESIGN OF STRUCTURAL ELEMENTS SHALL BE INCIDENTAL TO THEIR STRUCTURAL DESIGN AND SHALL BE BASED ON UNDERWRITERS LABORATORY OR GYPSUM ASSOCIATION DESIGN FOR FIRE RATED FLOOR, WALL AND ROOF ASSEMBLIES.
36. FLOOD RESISTANT DESIGN:
- A. FLOOD RESISTANT DESIGN OF FLOOD RESISTANT DESIGN OF STRUCTURAL ELEMENTS SHALL BE INCIDENTAL TO THEIR STRUCTURAL DESIGN AND SHALL BE BASED ON THE REQUIREMENTS STATED IN TITLE 44 CFR SECTIONS 59 AND 60, AND ON THOSE OF THE INDIVIDUAL COMMUNITY RATING AGENCIES FOR THE GOVERNMENTAL JURISDICTION WHERE THE CONSTRUCTION IS TO BE DONE.
  - B. HOWEVER, THE STRUCTURAL ENGINEER IS NOT RESPONSIBLE FOR IDENTIFYING AND SHOWING ON THE PLANS THE FLOOD ZONE CATEGORY, BASE FLOOD ELEVATION, AND THE FLOOR AND STORY HEIGHTS OF THE BUILDING IN RELATION TO THE BASE FLOOD ELEVATION. THIS INFORMATION IS CONSIDERED ARCHITECTURAL AND SITE RELATED AND SHALL BE PROVIDED TO THE STRUCTURAL ENGINEER BY THE CONTRACTING CLIENT OR HIS AGENT.
37. SPECIAL CONSTRUCTION:
- I. ALUMINUM STRUCTURAL COLUMNS:
    - A. ANY ALUMINUM STRUCTURES SHOWN IN THESE PLANS SUCH AS PORCH AND POOL ENCLOSURES OR GUARDRAILS AND HANDRAILS ARE FOR ARCHITECTURAL ILLUSTRATION ONLY AND ARE NOT PART OF THE STRUCTURAL DESIGN OR THE RESPONSIBILITY OF THE STRUCTURAL ENGINEER.
    - B. WHERE THE ALUMINUM STRUCTURE ATTACHES TO THE MAIN STRUCTURE OR IS INCORPORATED IN THE MAIN STRUCTURE, SHOP DRAWINGS FOR THESE STRUCTURES SHALL BE PROVIDED TO THE STRUCTURAL ENGINEER TO DETERMINE THEIR EFFECT ON THE MAIN STRUCTURE.
  - II. SWIMMING POOLS:
    - A. ANY SWIMMING POOL OR HOT TUBS SHOWN IN THESE PLANS ARE FOR ARCHITECTURAL ILLUSTRATION ONLY AND ARE NOT PART OF THE STRUCTURAL DESIGN OR THE RESPONSIBILITY OF THE STRUCTURAL DESIGN.
  - III. FENCES AND RETAINING WALLS:
    - A. ANY RENDERING OF FENCES, RETAINING WALLS OR EXTERIOR PLANTERS WHERE A SPECIFIC STRUCTURAL DETAIL IS NOT SHOWN FOR THEIR CONSTRUCTION ARE FOR ARCHITECTURAL ILLUSTRATION ONLY AND ARE NOT THE RESPONSIBILITY OF THE STRUCTURAL ENGINEER.
  - IV. DRIVEWAYS AND WALKWAYS:
    - A. ANY DRIVEWAYS OR WALKWAYS SHOWN IN THESE PLANS ARE FOR ARCHITECTURAL ILLUSTRATION PURPOSES ONLY AND ARE NOT PART OF THE STRUCTURAL DESIGN OR THE RESPONSIBILITY OF THE STRUCTURAL ENGINEER.

### Cladding Structural Information

This table was prepared using Windload Calculator Plus Software available from www.windcalcs.com

This information was created in accordance with Chapter 16 of the 2020 Florida Building Code. The Component and Cladding Pressures were generated using the method in Part 2 of Chapter 30 of ASCE 7-16.

#### Floor & Roof Live Loads ( R-3 • 2-Family Dwellings )

Attics:	20 psf w/ storage, 10 psf w/o storage
Habitable Attics, Bedroom:	30 psf
All Other Rooms:	40 psf
Garage:	40 psf
Roofs:	20 psf

(Balcony and Deck live loads are 150% of the adjacent space served.)

#### Wind Design Data

Ultimate Wind Speed:	145 mph	Nominal Wind Speed:	112 mph
Risk Category:	II	Wind Exposure:	B
Enclosure Classification:	Enclosed	End Zone Width (a):	4.00 ft.
Internal Pressure Coefficient:	0.18	Roof Geometry:	Hip
Roof Slope:	5.0 in 12 (22.6°)	Mean Roof Height:	13 ft.

(The Ultimate Wind speed was used to determine the Component and Cladding design pressures.)

(This Building is in a Wind-Borne Debris Region, and all exterior glazed openings shall be protected from wind-borne debris.)

#### Components and Cladding

Roof Zone 1:	+23.2 psf max., -41.6 psf min.
Roof Zone 2e:	+23.2 psf max., -57.4 psf min.
Roof Zone 2r:	+23.2 psf max., -57.4 psf min.
Roof Zone 3:	+23.2 psf max., -57.4 psf min.
Overhang at Roof Zone 1:	-49.8 psf min.
Overhang at Roof Zone 2e:	-64.4 psf min.
Overhang at Roof Zone 2r:	-64.4 psf min.
Overhang at Roof Zone 3:	-77.1 psf min.
Wall Zone 4:	+31.1 psf max., -33.7 psf min.
Wall Zone 5:	+31.1 psf max., -41.7 psf min.
9' X 7' Garage Door:	+27.4 psf max., -31.6 psf min.

Design Soil Bearing Capacity: 2,000 psf

WIND LOAD DESIGN DATA

WINDCHESTER MODEL

A.E.C.S. 21019

S4

DEEB FAMILY HOMES, LTD.

PLAN DATE

02-24-2021

BUILDING 63  
RESERVE AT HUNTERS RIDGE  
PHASE THREE

I HEREBY CERTIFY THAT I HAVE PERFORMED THE ATTACHED DESIGN TO COMPLY WITH 145 MPH ULTIMATE WIND LOADS AND IT IS IN COMPLIANCE WITH SECT. 301 OF THE 2020 FLORIDA RESIDENTIAL BUILDING CODE SEALED FOR STRUCTURE ONLY  
SIGNED: [Signature] RICHARD E. ALLEN P.E. #56920

ALLEN ENGINEERING & CONSTRUCTION SERVICES  
RICH ALLEN PROFESSIONAL ENGINEER  
P.E. # 56920 C.A. # 9542  
P.O. BOX 351  
NEW PORT RICHEY, FL. 34656  
727-842-6100  
rehall@apec@gmail.com

**NOTES**

- 1) THE FOUNDATION SYSTEM FOR THIS PLAN IS DESIGNED FOR A MINIMUM ALLOWABLE SOIL BEARING PRESSURE OF 2,000 P.S.F. WITH NO SOILS REPORT OR INFORMATION PROVIDED.
- 2) FOOTINGS TO BEAR MIN. 12" BELOW GRADE.
- 3) FOOTINGS TO BEAR ON UNDISTURBED SOIL OR FILL COMPACTED TO 95% MOD. PROCTOR BETWEEN LESS THAN 12" LIFTS.
- 4) ALL BEARING SOILS TO BE FREE OF DEBRIS AND ORGANIC MATERIAL.
- 5) REFER TO STRUCTURAL ENGINEER NOTES.

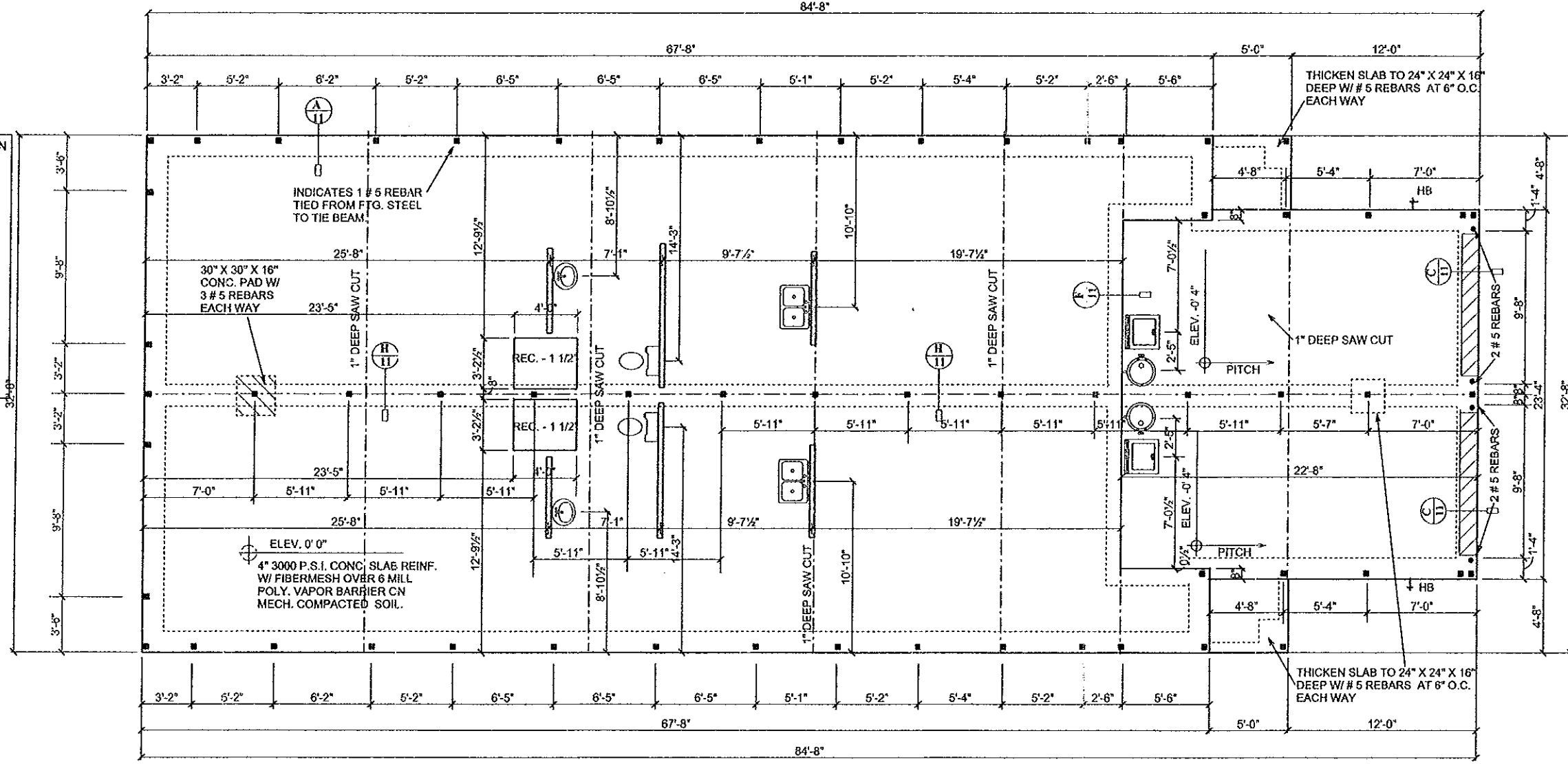

SLAB PLAN

SCALE 1/8" = 1'-0"

A.E.C.S. 21019

WINDCHESTER MODEL

**1**

DEEB FAMILY HOMES, LTD.

PLAN DATE

02-24-2021

**BUILDING 63**  
RESERVE AT HUNTERS RIDGE  
PHASE THREE

HEREBY CERTIFY THAT I HAVE PERFORMED THE ATTACHED DESIGN TO COMPLY WITH 145 MPH ULTIMATE WIND LOADS AND IT IS IN COMPLIANCE WITH SECT. 301 OF THE 2020 FLORIDA RESIDENTIAL BUILDING CODE SEALED FOR STRUCTURE ONLY

SIGNED *Richard E. Allen*  
RICHARD E. ALLEN P.E. #56920

ALLEN ENGINEERING & CONSTRUCTION SERVICES  
RICH ALLEN PROFESSIONAL ENGINEER  
P.E. #56920 C.A. # 9442

P.O. BOX 351  
NEW PORT RICHEY, FL. 34656  
727-842-6100  
richallenpe@gmail.com

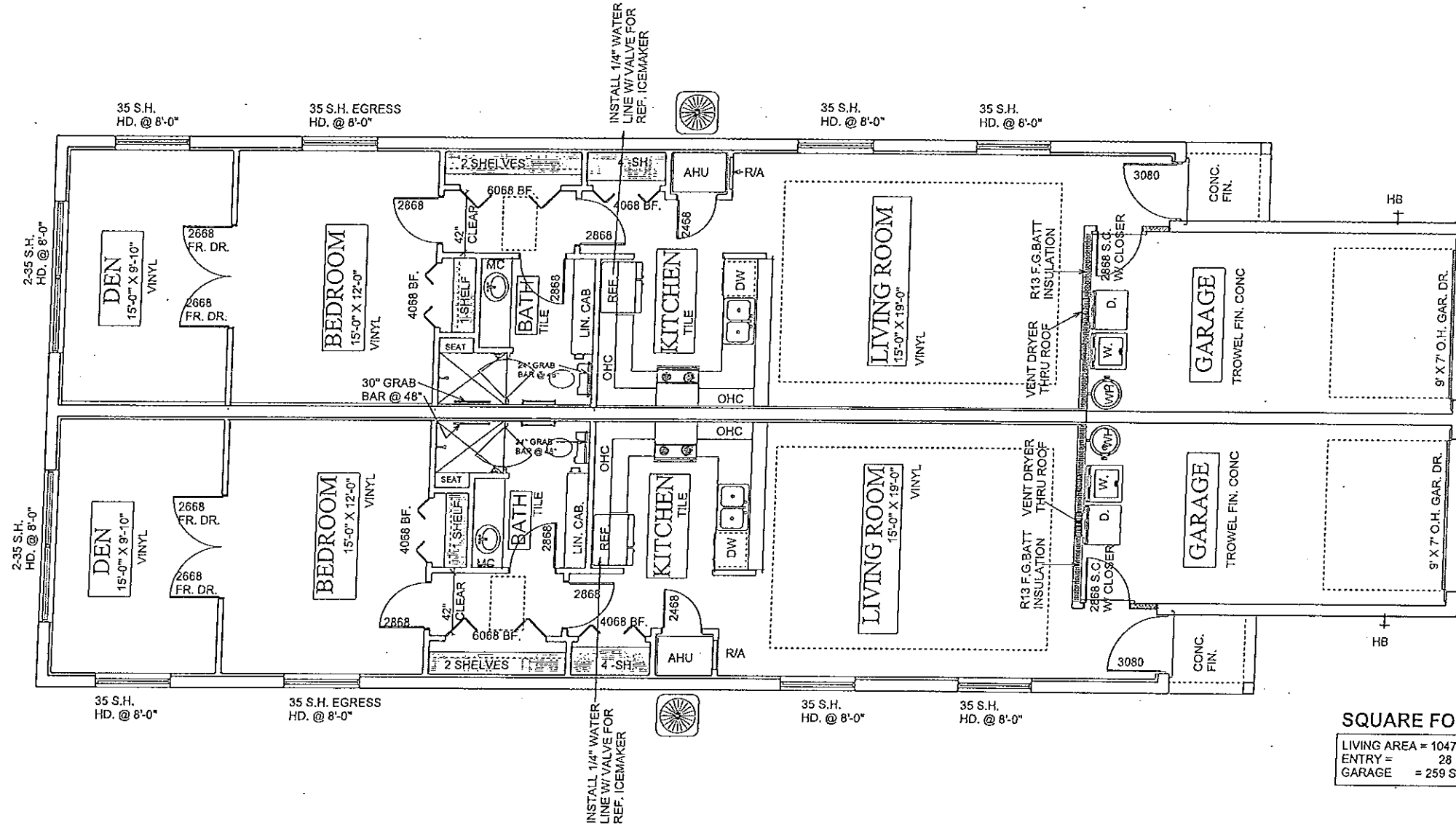

**SQUARE FOOTAGES**

LIVING AREA	= 1047 S.F.
ENTRY	= 28 S.F.
GARAGE	= 259 S.F.

FLOOR PLAN NOTES

SCALE 1/8" = 1'-0"

A.E.C.S. 00000

WINDCHESTER MODEL

DEEB FAMILY HOMES, LTD.

**2**

PLAN DATE

07-28-2020

**BUILDING 00**  
RESERVE AT HUNTERS RIDGE  
PHASE THREE

I HEREBY CERTIFY THAT I HAVE PERFORMED THE ATTACHED DESIGN TO COMPLY WITH 145 MPH ULTIMATE WIND LOADS AND IT IS IN COMPLIANCE WITH SECT. 301 OF THE 2020 FLORIDA RESIDENTIAL BUILDING CODE SEALED FOR STRUCTURE ONLY

SIGNED  
RICHARD E. ALLEN P.E. #56920

ALLEN ENGINEERING & CONSTRUCTION SERVICES  
RICH ALLEN PROFESSIONAL ENGINEER  
P.E. # 56920 C.A. # 9542  
P.O. BOX 351  
NEW PORT RICHEY, FL. 34656  
727-942-6100  
richallenpc@gmail.com

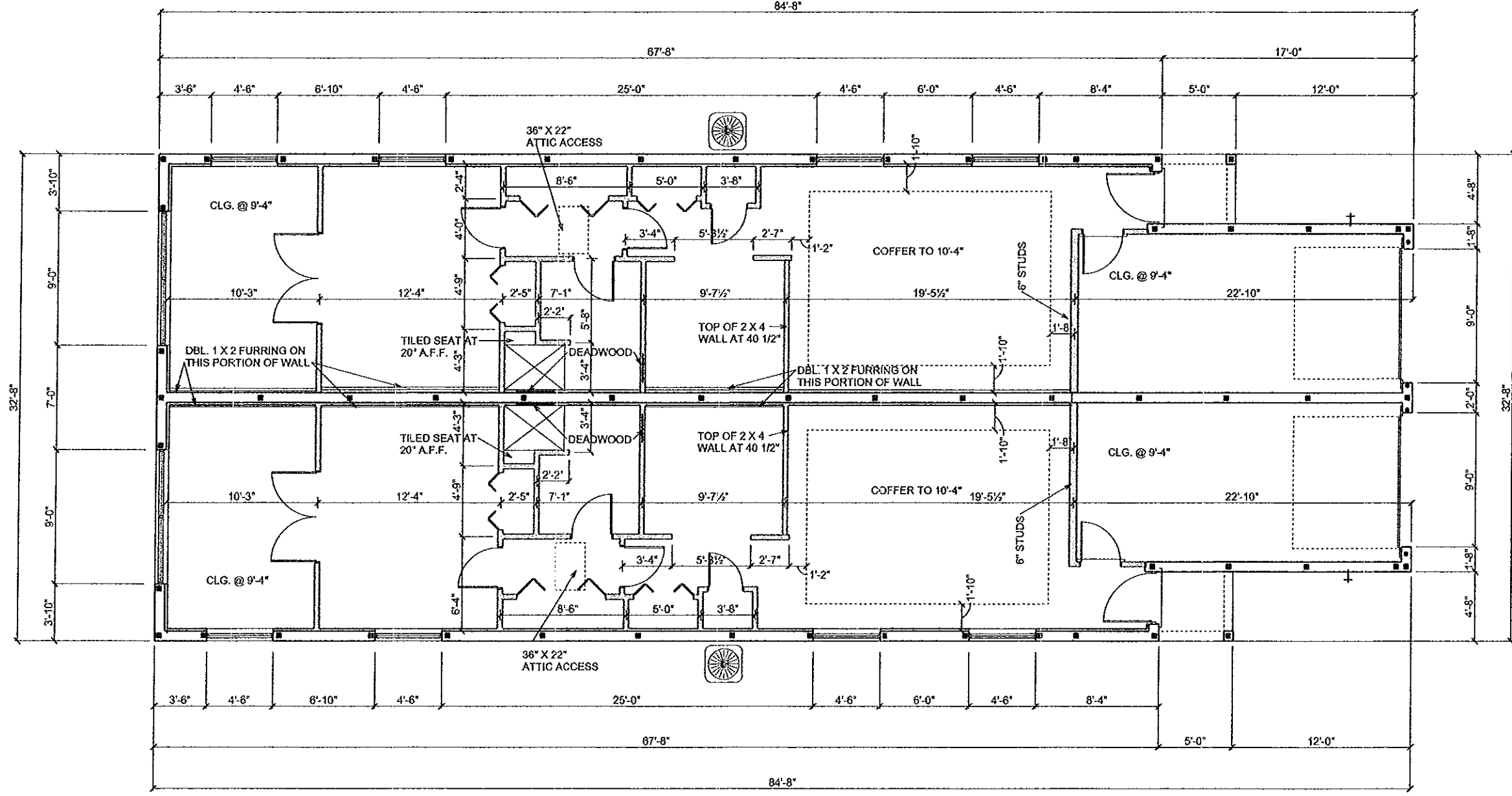

DIMENSION PLAN

SCALE 1/8" = 1'-0"

A.E.C.S. 21019

WINDCHESTER MODEL

3

DEEB FAMILY  
HOMES, LTD.

PLAN DATE

02-24-2021

BUILDING 63  
RESERVE AT HUNTERS RIDGE  
PHASE THREE

I HEREBY CERTIFY THAT I HAVE  
PERFORMED THE ATTACHED DESIGN  
TO COMPLY WITH 145 MPH ULTIMATE  
WIND LOADS AND IT IS IN COMPLIANCE  
WITH SECT. 901 OF THE 2020 FLORIDA  
RESIDENTIAL BUILDING CODE  
SEALED FOR STRUCTURE ONLY

SIGNED  
RICHARD E. ALLEN

P.E. #56920

ALLEN ENGINEERING &  
CONSTRUCTION SERVICES  
RICH ALLEN, PROFESSIONAL ENGINEER  
P.E. # 56920 C.A. # 9542

P.O. BOX 351  
NEW PORT RICHEY, FL. 34656  
727-842-6100  
richallenpo@gmail.com



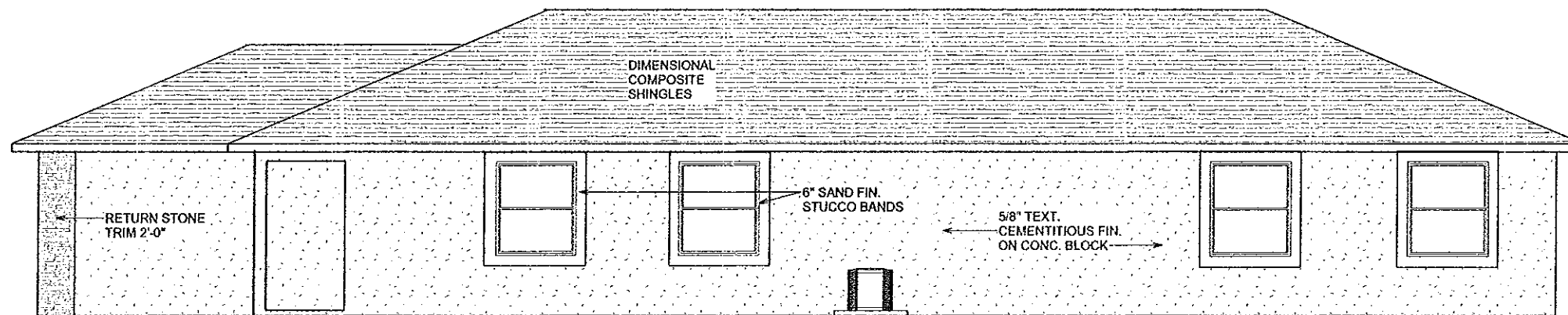

RIGHT & LEFT HAND ELEVATIONS

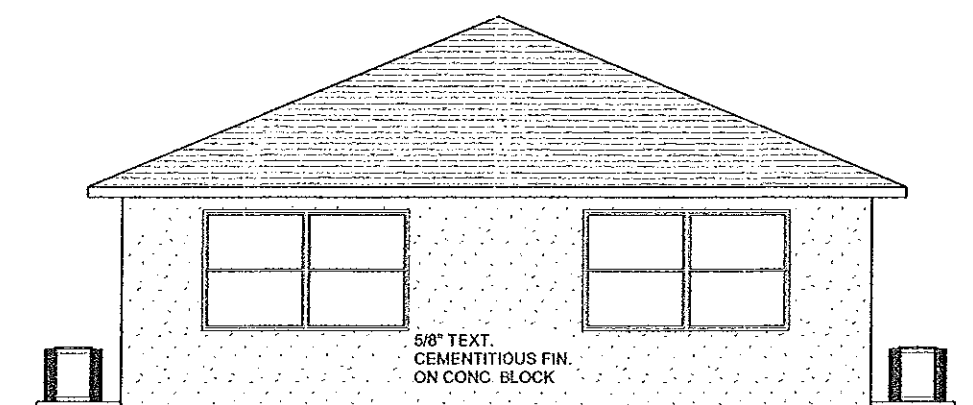

REAR ELEVATION

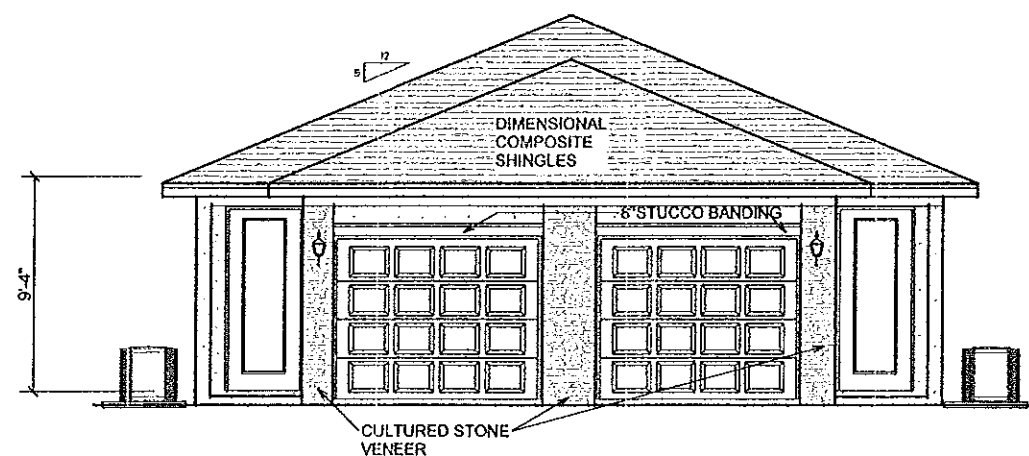

FRONT ELEVATION

EXTERIOR ELEVATIONS

SCALE 1/8" = 1'-0" A.E.C.S. 21019

WINDCHESTER MODEL

DEEB FAMILY HOMES, LTD.

BUILDING 63  
RESERVE AT HUNTERS RIDGE  
PHASE THREE

PLAN DATE

02-24-2021

4

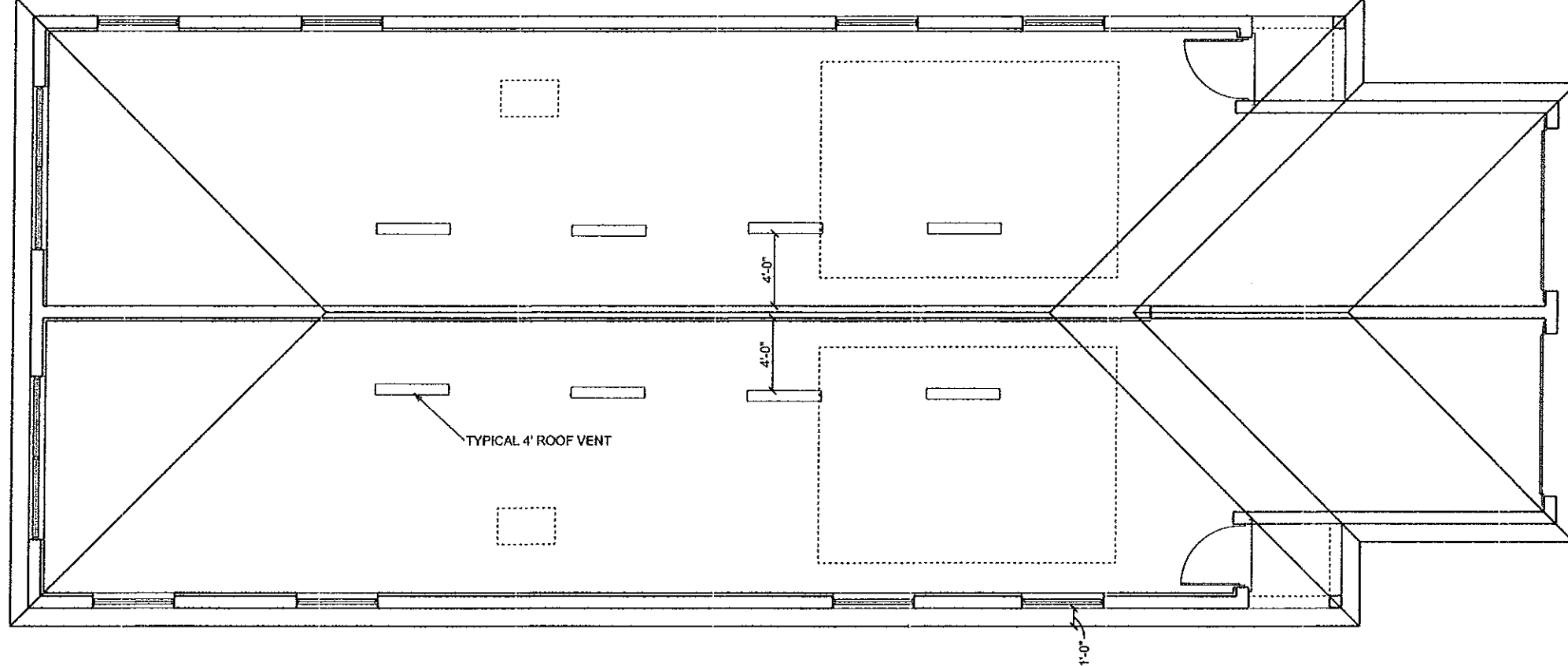

TOTAL NET FREE VENTILATING AREA SHALL NOT BE LESS THAN 1 TO 300 PROVIDED THAT AT LEAST 50 % AND NOT MORE THAN 80 % IS PROVIDED BY VENTILATORS LOCATED IN THE UPPER PORTION OF THE SPACE TO BE VENTILATED PER SECT. R806.2

TOTAL AREA TO BE VENTILATED = 1174 S.F.  
 1174/300 = 3.91 S.F. OR 564 SQUARE INCHES.

ROOF VENTS ARE RATED AT 36 SQUARE INCHES OF OPENING PER LINEAL FT.  
 564 S.I./36 S.I. = 15.6' LINEAL FEET REQUIRED.

INSTALLATION FOR THIS ROOF IS 16 OF ROOF VENTING ( 4'-4" VENTS )

ROOF PLAN

SCALE 1/8" = 1'-0"

A.E.C.S. 21019

WINDCHESTER MODEL

6

DEEB FAMILY HOMES, LTD.

PLAN DATE
02-24-2021

**BUILDING 63**  
 RESERVE AT HUNTERS RIDGE  
 PHASE THREE

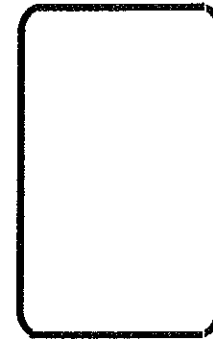

**IMPORTANT NOTE:**

THIS FRAMING PLAN IS DIAGRAMMATIC IN NATURE AND IS PROVIDED FOR ILLUSTRATION PURPOSES ONLY. TRUSS MANUFACTURER TO PROVIDE SEPARATE LAYOUT AND TRUSS COMPONENT DESIGN SIGNED AND SEALED BY A PROFESSIONAL ENGINEER AND REVIEWED BY P.E. OF RECORD.

**FASTENER NOTES**

(1) FOR MGT USE 5/8" X 6" TITEN HD. CONC. BOLTS  
 (2) FOR HGT-2, FOLLOW MFR'ER. INSTRUCTIONS FOR EMBEDDING BOLTS- MECH. BOLT CANNOT SATISFY CRITICAL SPACING.

NOTE: INSTALL MOISTURE BARRIER BETWEEN MASONRY & UNTREATED WOOD

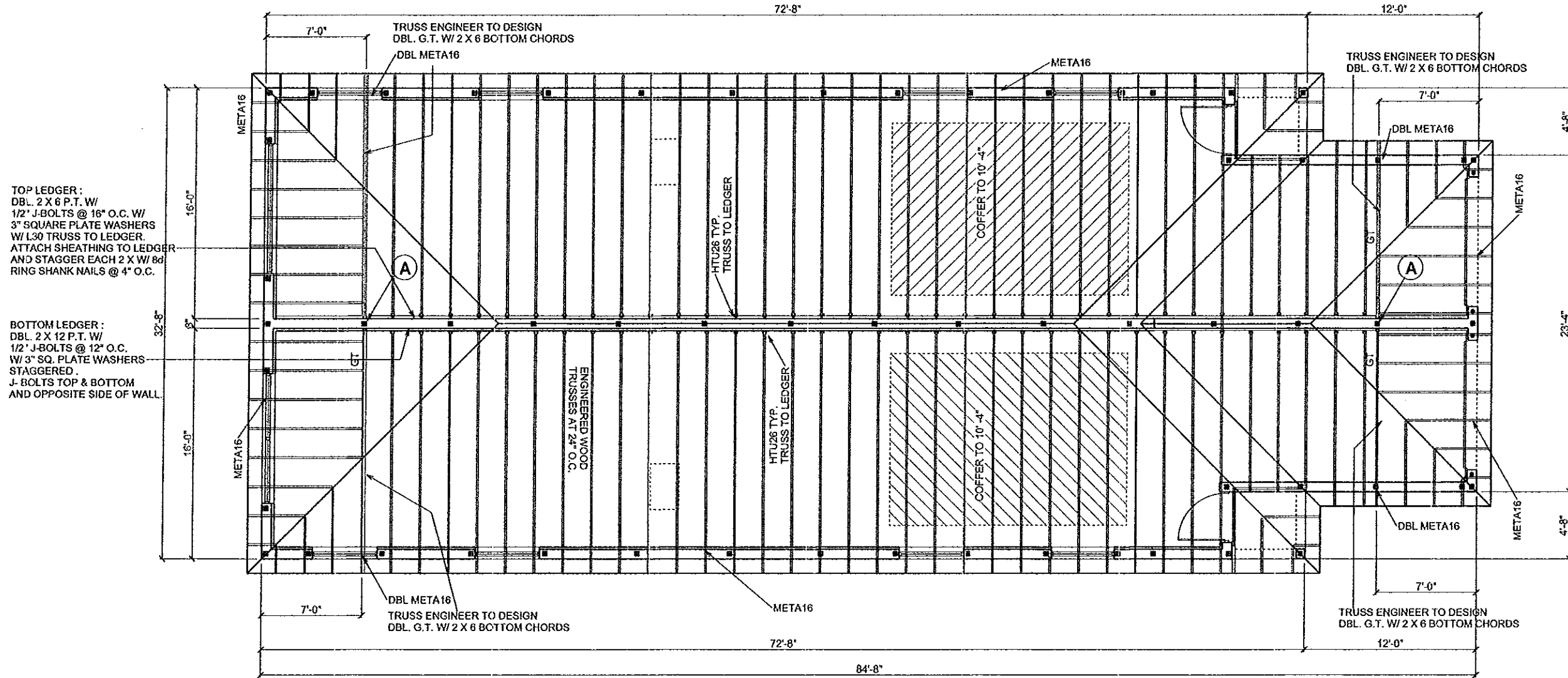

TOP LEDGER:  
 DBL 2 X 6 P.T. W/  
 1/2" J-BOLTS @ 16" O.C. W/  
 3" SQUARE PLATE WASHERS  
 W/ L30 TRUSS TO LEDGER.  
 ATTACH SHEATHING TO LEDGER  
 AND STAGGER EACH 2 X W 8d  
 RING SHANK NAILS @ 4" O.C.

BOTTOM LEDGER:  
 DBL 2 X 12 P.T. W/  
 1/2" J-BOLTS @ 12" O.C.  
 W/ 3" SQ. PLATE WASHERS  
 STAGGERED.  
 J- BOLTS TOP & BOTTOM  
 AND OPPOSITE SIDE OF WALL.

**(A)** END LEDGER PRIOR TO GIRDER TRUSS.  
 CONNECT G.T. DIRECTLY TO C.M.U. W/  
 HU26-2 ( MAX )

**TRUSS PLAN** SCALE 1/8" = 1'-0"

**WINDCHESTER MODEL**

**A.E.C.S. 21019**

**BUILDING 63**  
 RESERVE AT HUNTERS RIDGE  
 PHASE THREE

**PLAN DATE**  
 02-24-2021

**DEEB FAMILY HOMES, LTD.**

**6A**

ALLEN ENGINEERING & CONSTRUCTION SERVICES  
 RICH ALLEN PROFESSIONAL ENGINEER  
 P.E. # 56920 C.A. # 9542  
 P.O. BOX 351  
 NEW PORT RICHEY, FL. 34656  
 727-842-6100  
 richallenc@icloud.com

HEREBY CERTIFY THAT I HAVE PERFORMED THE ATTACHED DESIGN TO COMPLY WITH 145 MPH ULTIMATE WIND LOADS AND IT IS IN COMPLIANCE WITH SECT. 301 OF THE 2020 FLORIDA RESIDENTIAL BUILDING CODE SEALED FOR STRUCTURE ONLY

SIGNED: *[Signature]*  
 RICHARD E. ALLEN P.E. #56920



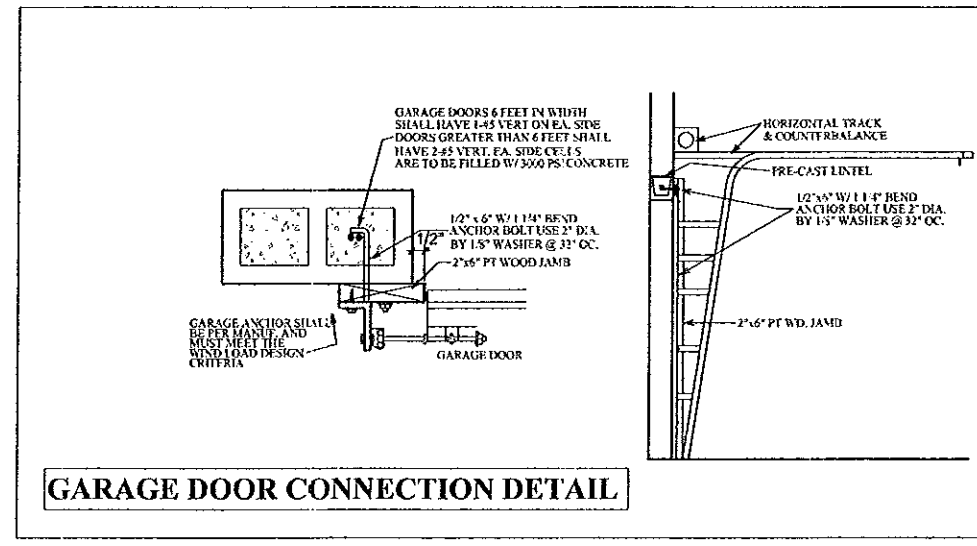
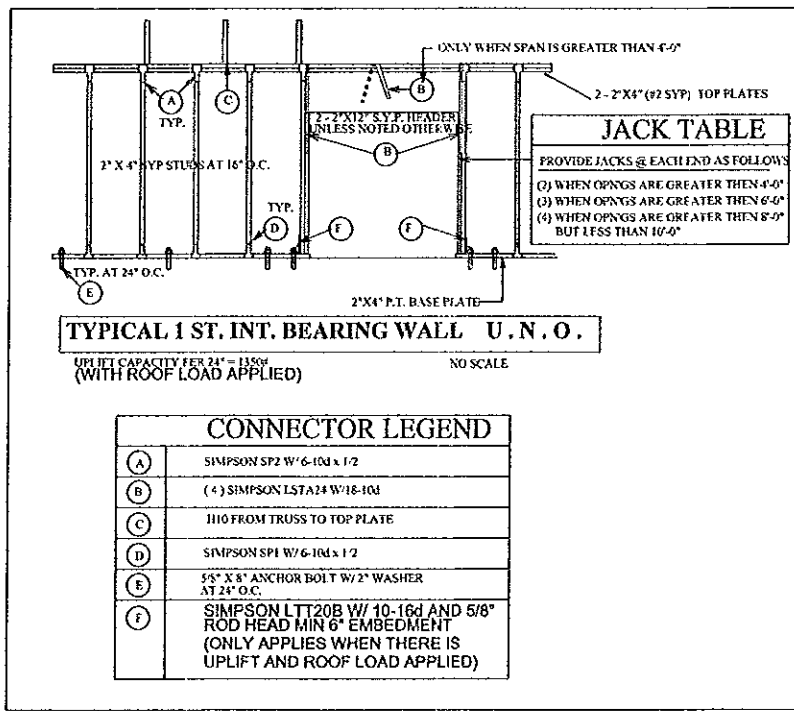
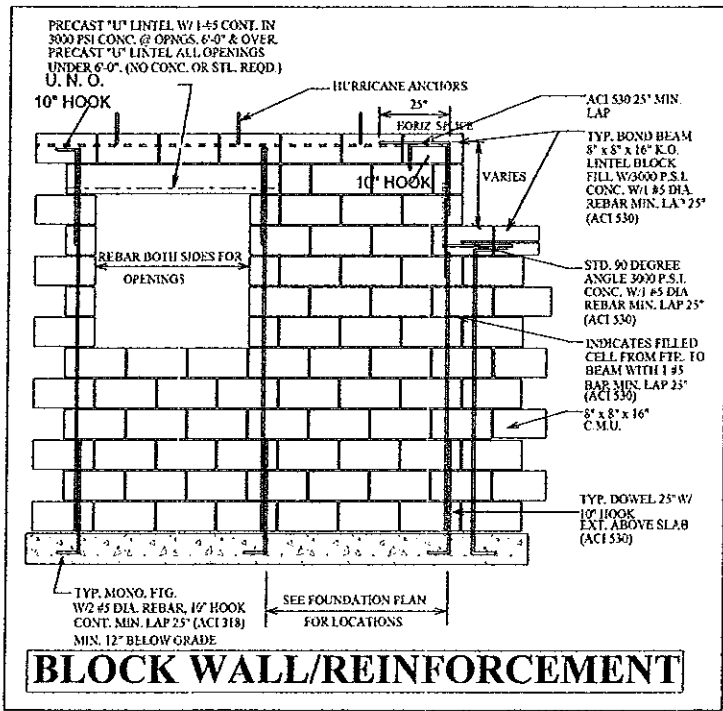
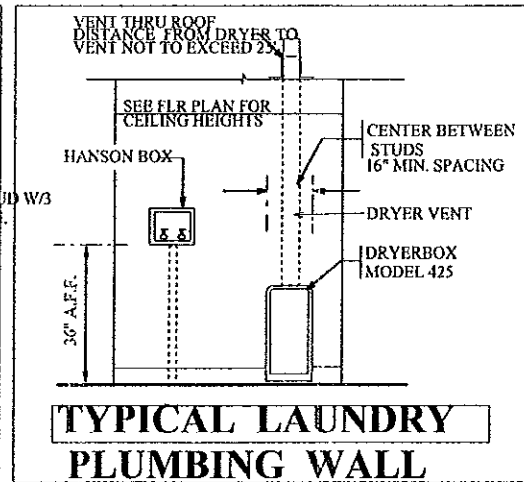
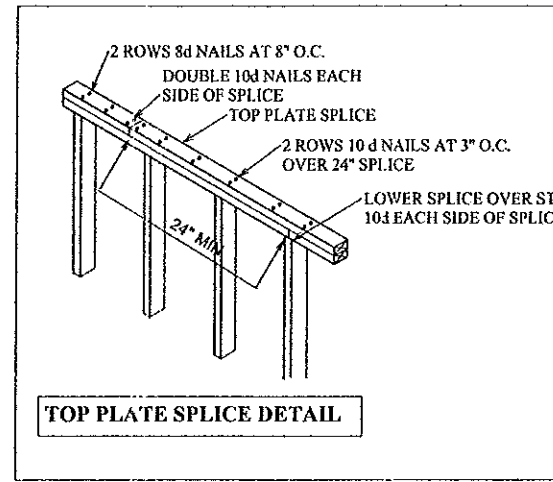
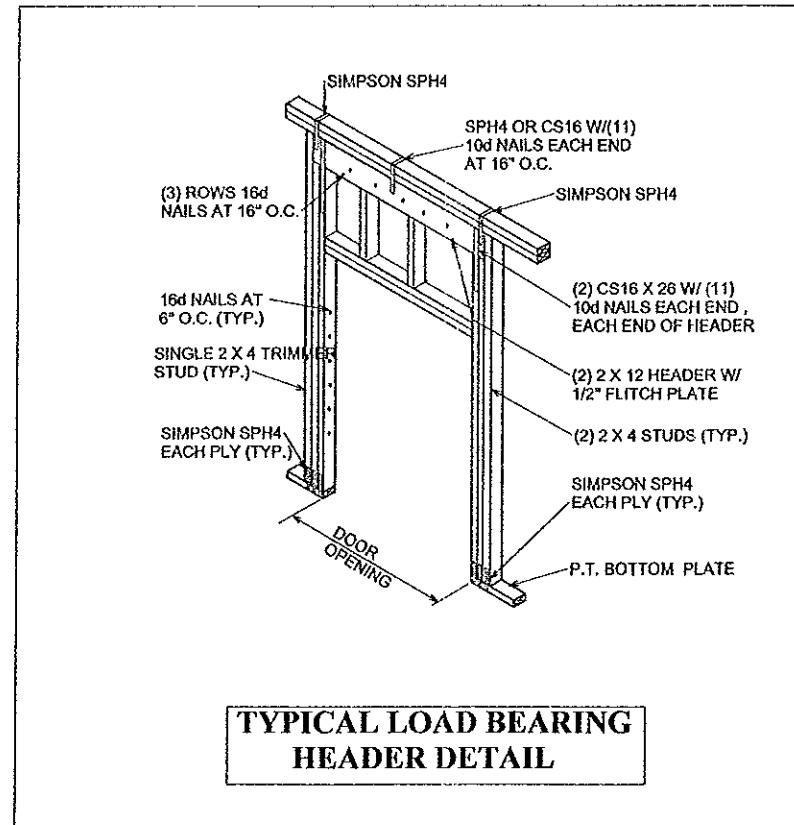
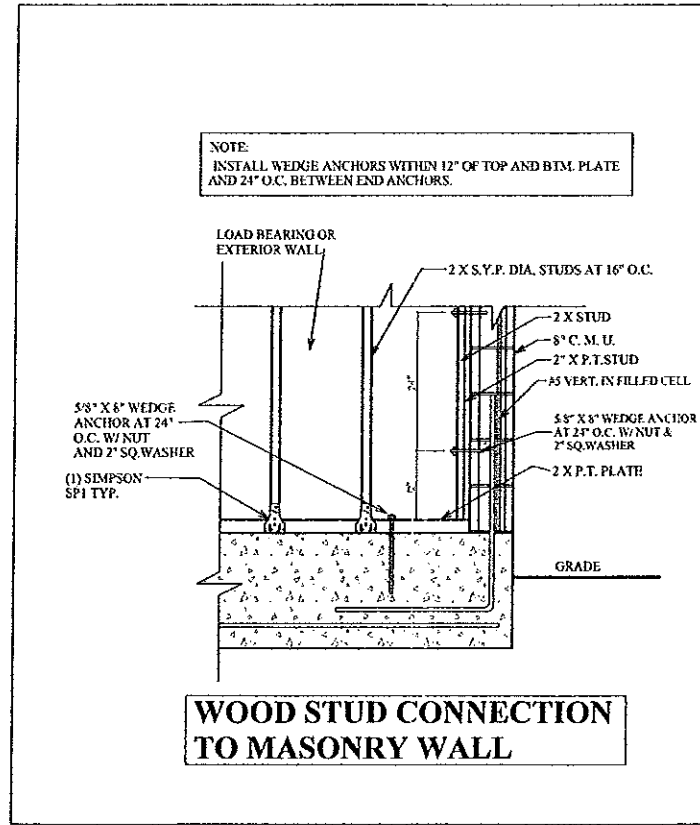

**WINDCHESTER MODEL**

**A.E.C.S. 21019**

**BUILDING 63**

RESERVE AT HUNTERS RIDGE PHASE THREE

**CONST. DETAILS**

**DEEB FAMILY HOMES, LTD.**

**8**

ALLEN ENGINEERING & CONSTRUCTION SERVICES  
RICH ALLEN PROFESSIONAL ENGINEER  
P.E. # 56920 C.A. # 9542

P.O. BOX 351  
NEW PORT RICHEY, FL. 34656  
727-842-6100  
richallenpe@gmail.com

I HEREBY CERTIFY THAT I HAVE PERFORMED THE ATTACHED DESIGN TO COMPLY WITH 145 MPH ULTIMATE WIND LOADS AND IT IS IN COMPLIANCE WITH SECT. 301 OF THE 2020 FLORIDA RESIDENTIAL BUILDING CODE SEALED FOR STRUCTURE ONLY

SIGNED: *[Signature]*  
RICHARD E. ALLEN P.E. #56920

PLAN DATE: 02-24-2021

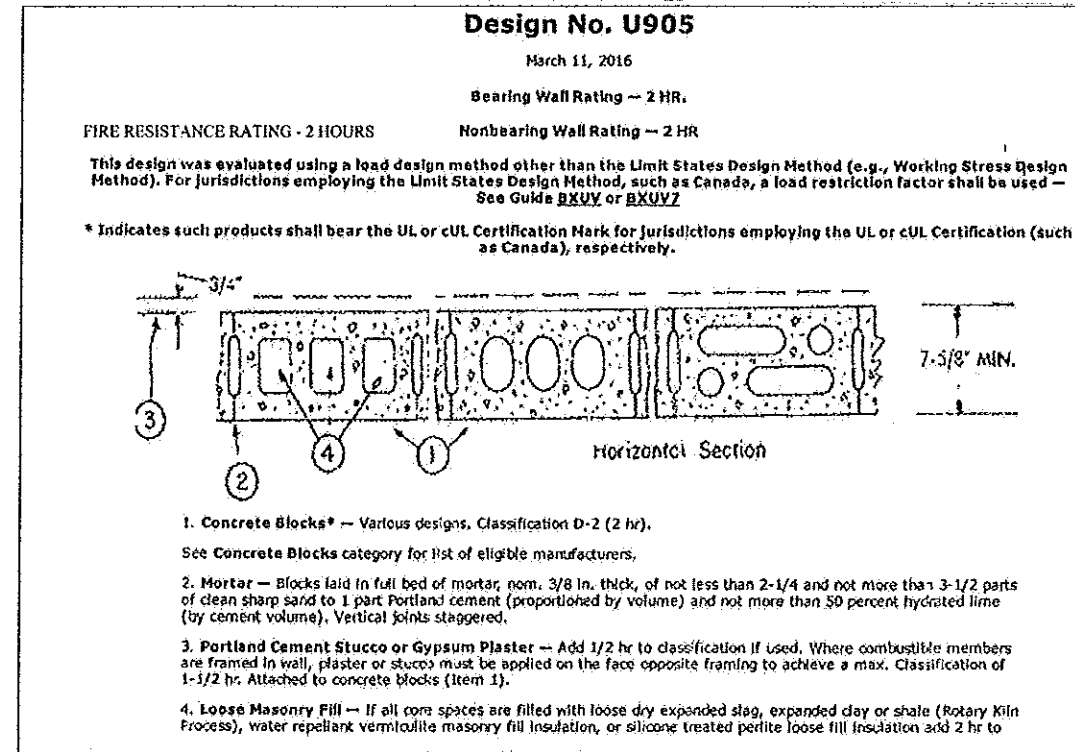
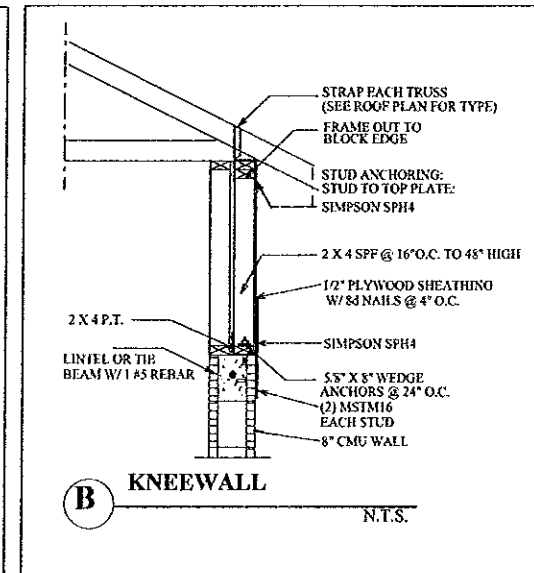
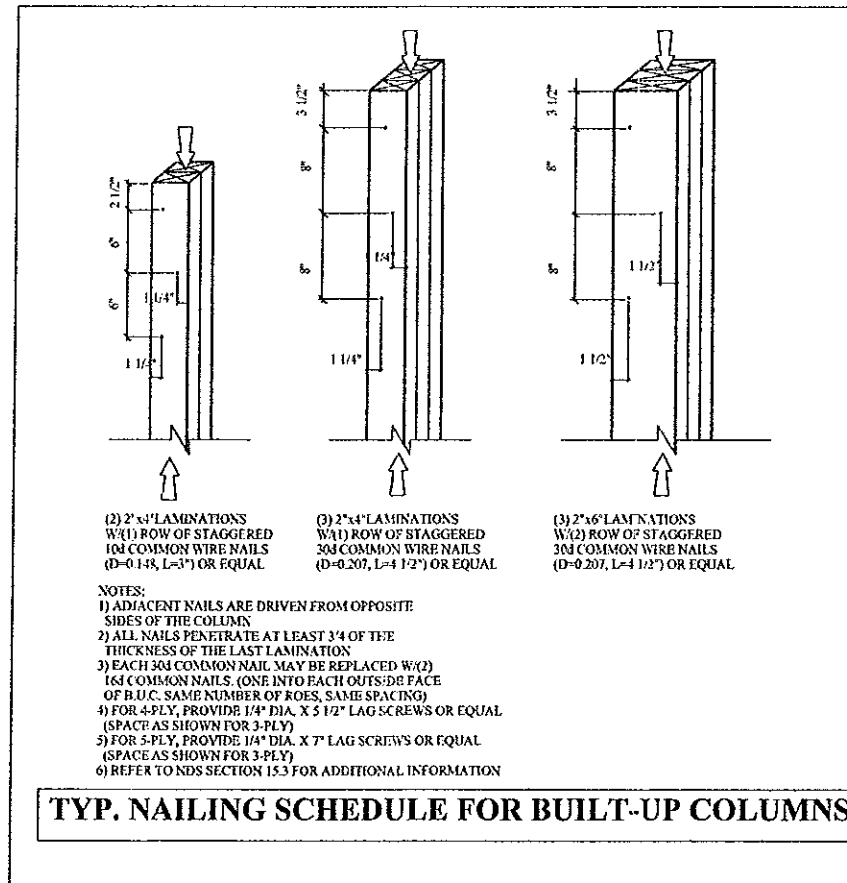
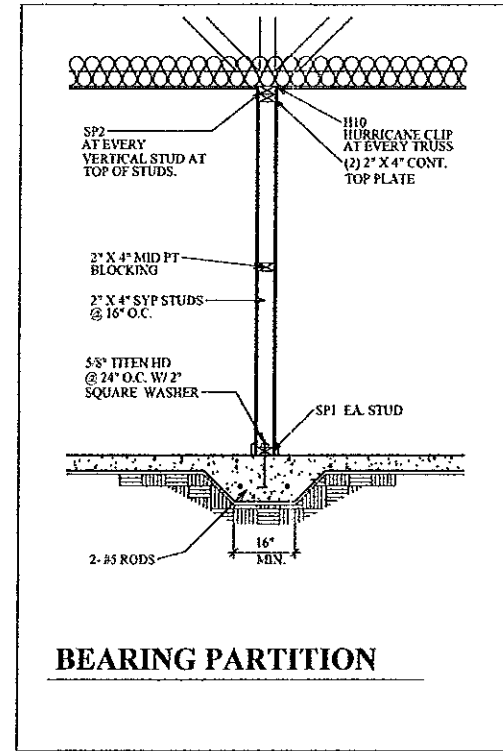
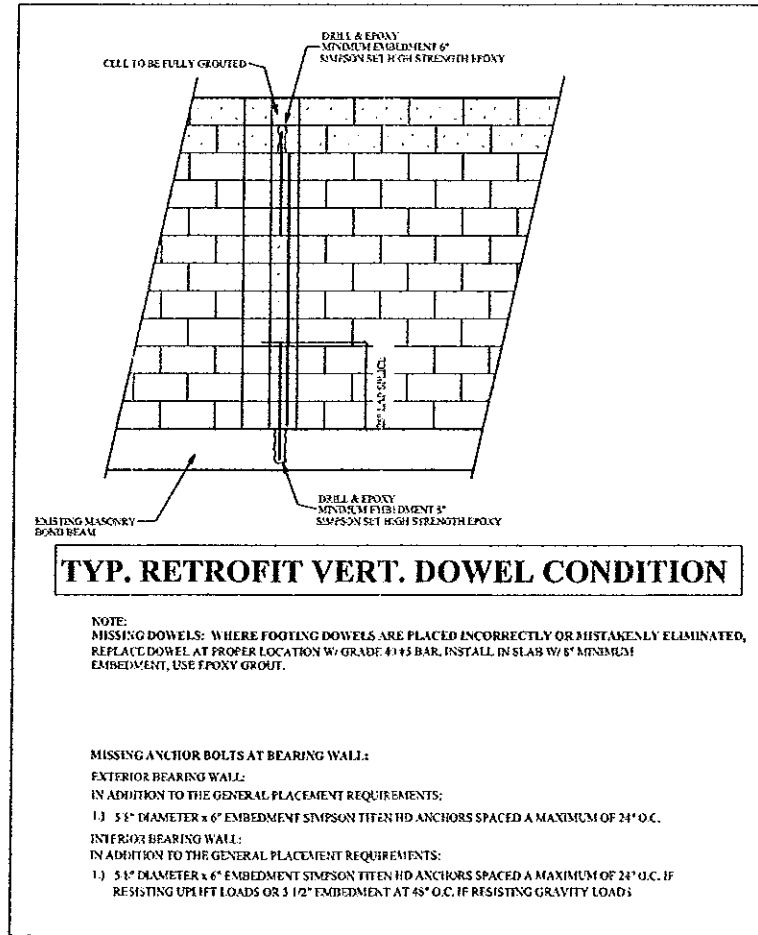

**WINDCHESTER MODEL**

**A.E.C.S. 21019**

**CONSTRUCTION DETAILS**

ALLEN ENGINEERING & CONSTRUCTION SERVICES  
RICH ALLEN PROFESSIONAL ENGINEER  
P.E. # 56920 C.A. # 9542  
P.O. BOX 351  
NEW PORT RICHEY, FL. 34656  
727-842-6100  
richallenpe@gmail.com

HEREBY CERTIFY THAT I HAVE PERFORMED THE ATTACHED DESIGN TO COMPLY WITH 145 MPH ULTIMATE WIND LOADS AND IT IS IN COMPLIANCE WITH SECT. 901 OF THE 2020 FLORIDA RESIDENTIAL BUILDING CODE SEALED FOR STRUCTURE ONLY  
SIGNED: *[Signature]*  
RICHARD E. ALLEN P.E. #56920

**BUILDING 63**  
RESERVE AT HUNTERS RIDGE  
PHASE THREE

PLAN DATE
02-24-2021

DEEB FAMILY HOMES, LTD.

**9**

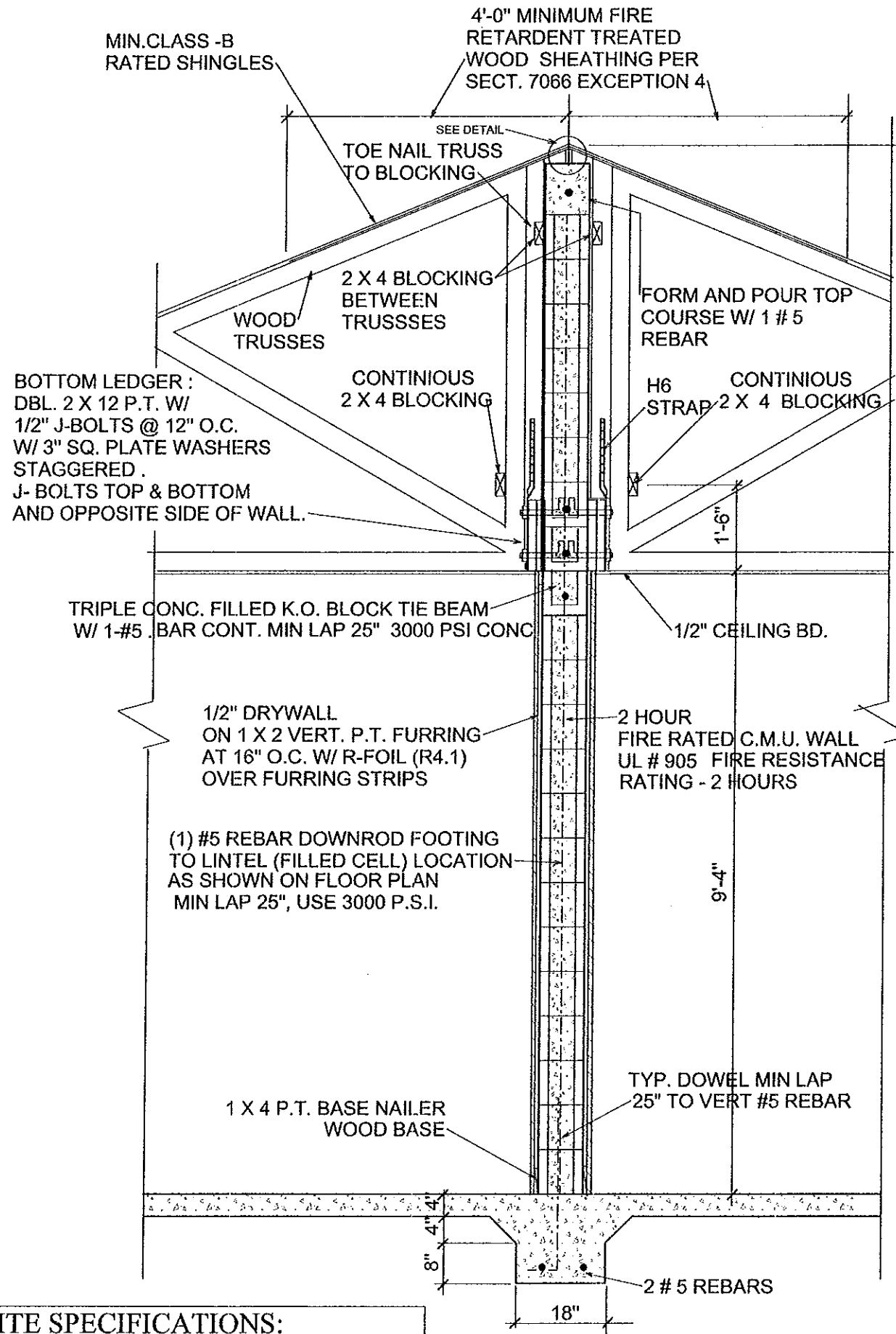

**TERMITE SPECIFICATIONS:**  
 INSTALL "BORA-CARE" TERMITE PROTECTION SYSTEM PER MANUF'. SPECIFICATIONS

**FIREWALL DETAIL**

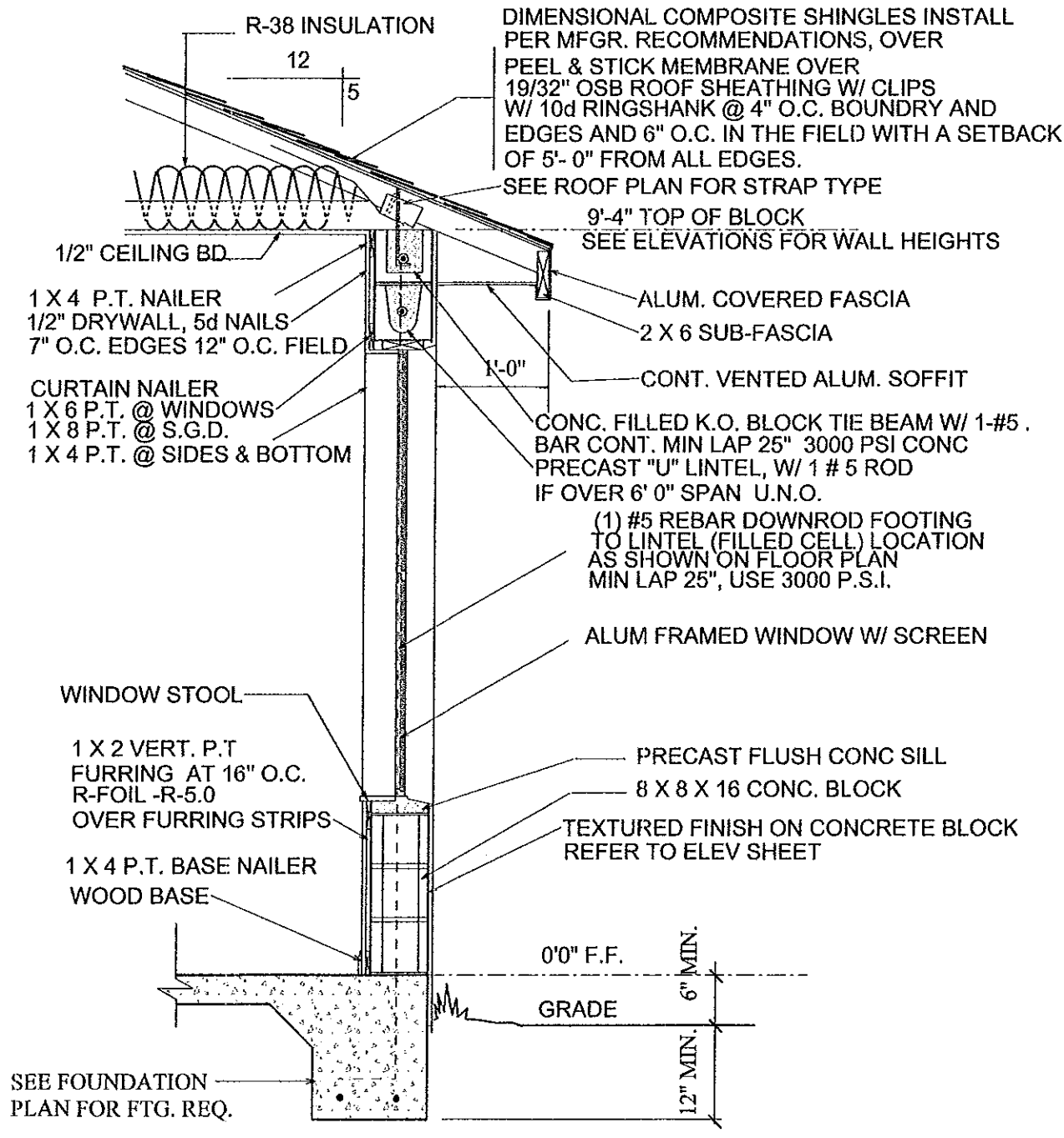
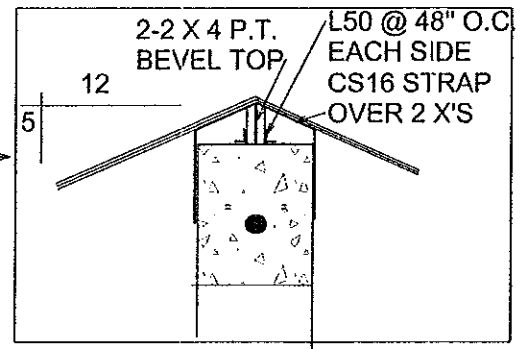

**TYPICAL WALL SECTION**

WINDCHESTER MODEL

A.E.C.S. 21019

CONSTRUCTION DETAILS

ALLEN ENGINEERING & CONSTRUCTION SERVICES  
 RICH ALLEN PROFESSIONAL ENGINEER  
 P.E. # 56920 C.A. # 9542  
 P.O. BOX 351  
 NEW PORT RICHEY, FL. 34656  
 727-842-6100  
 richallenpe@gmail.com

HEREBY CERTIFY THAT I HAVE PERFORMED THE ATTACHED DESIGN TO COMPLY WITH 145 MPH ULTIMATE WIND LOADS AND IT IS IN COMPLIANCE WITH SECT. 901 OF THE 2020 FLORIDA RESIDENTIAL BUILDING CODE SEALED FOR STRUCTURE ONLY  
 RICHARD E. ALLEN P.E. # 66920

**BUILDING 63**  
 RESERVE AT HUNTERS RIDGE  
 PHASE THREE

PLAN DATE
02-24-2021

DEEB FAMILY HOMES, LTD.

**10**

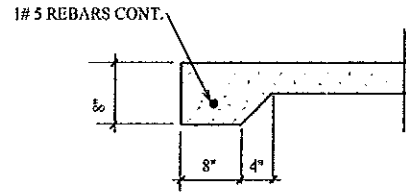

**8" THICKENED SLAB (J)**

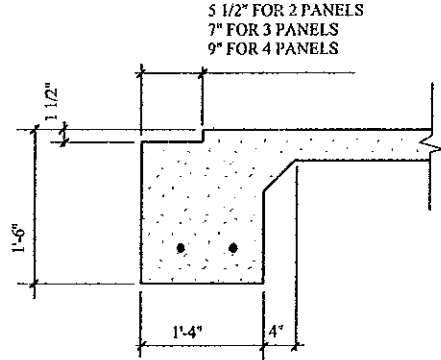

**SLIDING GLASS DR. RECESS (D)**

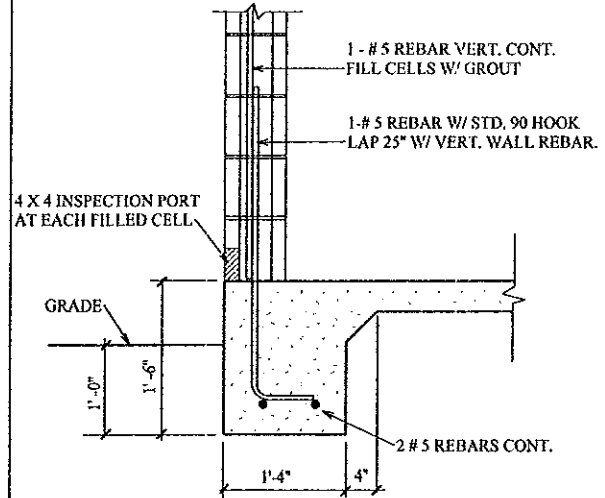

**TYPICAL ONE STORY (A)**

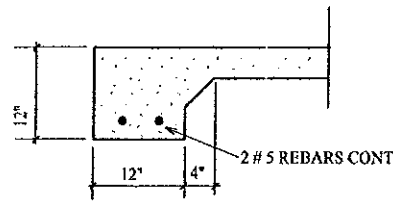

**12" THICKENED SLAB (K)**

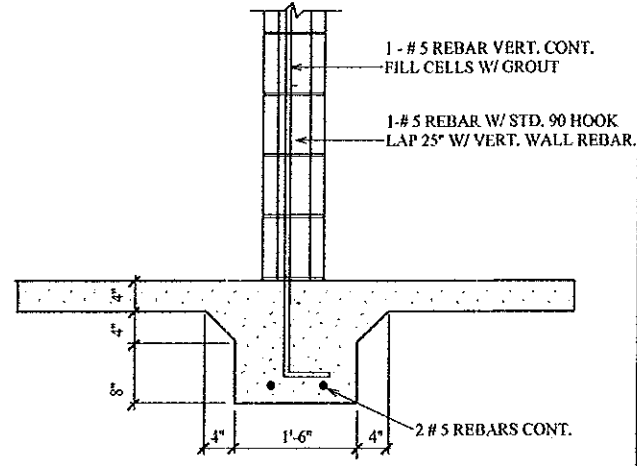

**INTERIOR BEARING FTG. (H)**

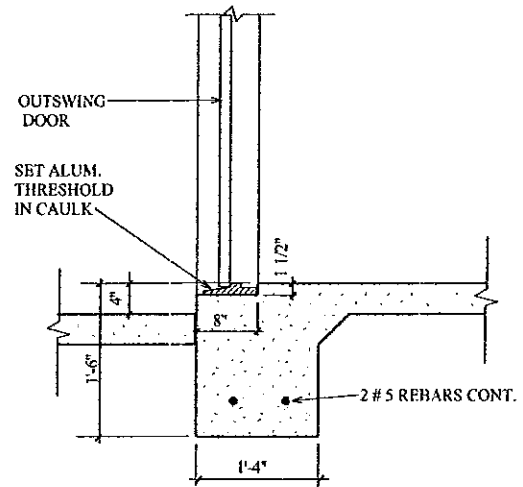

**EXTERIOR DOOR RECESS (B)**

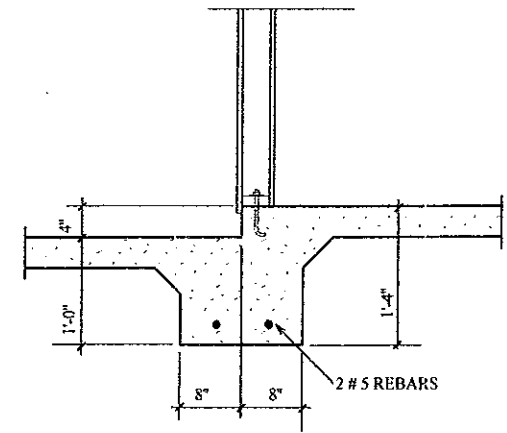

**BEARING GARAGE STEP (I)**

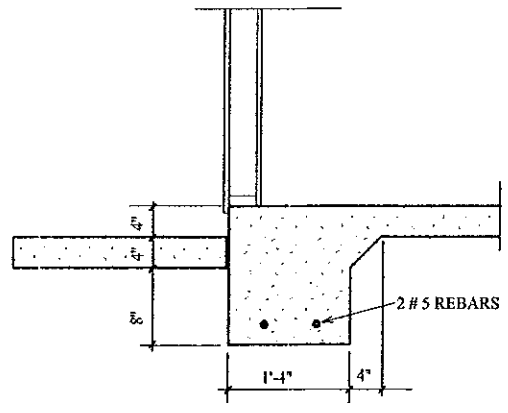

**NON-BRG. GARAGE STEP (F)**

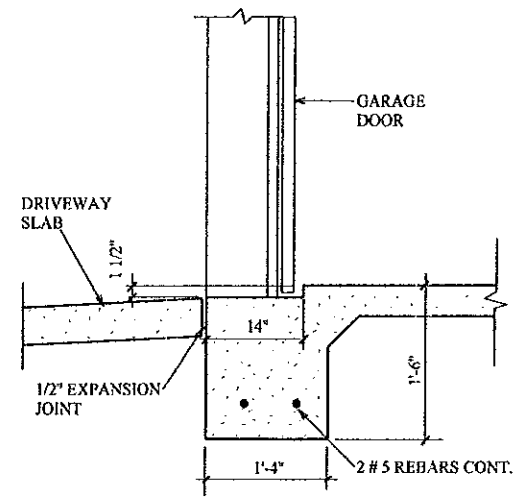

**GARAGE DOOR RECESS (C)**

**WINDCHESTER MODEL**

**A.E.C.S. 21019**

**FOOTING DETAILS**

**ALLEN ENGINEERING & CONSTRUCTION SERVICES**  
 RICH ALLEN, PROFESSIONAL ENGINEER  
 P.E. # 56920 C.A. # 9542  
 P.O. BOX 351  
 NEW PORT RICHEY, FL. 34656  
 727-842-6100  
 richallenpe@gmail.com

I HEREBY CERTIFY THAT I HAVE PERFORMED THE ATTACHED DESIGN TO COMPLY WITH 145 MPH ULTIMATE WIND LOADS AND IT IS IN COMPLIANCE WITH SECT. 301 OF THE 2020 FLORIDA RESIDENTIAL BUILDING CODE SEALED FOR STRUCTURE ONLY  
 SIGNED: [Signature]  
 RICHARD C. ALLEN P.E. #56920

**BUILDING 63**  
 RESERVE AT HUNTERS RIDGE  
 PHASE THREE

**PLAN DATE**

02-24-2021

**DEEB FAMILY HOMES, LTD.**

**11**



